

# Adjustable Shelf

For A/V Components or Microwaves

1. Versatile design ideal for stacking multiple A/V components or supporting a microwave
2. Adjustable width up to 18.44" (468 mm) and depth range of 14.86" to 23" (377-584 mm)
3. Snap-on cover hides wall plate and mounting hardware
4. Adjustment knobs allow for easy leveling of components
5. Embossed arms with screw holes secure components to shelf
6. 100 lb (45 kg) load capacity allows stacking of multiple components, ideal for A/V closets

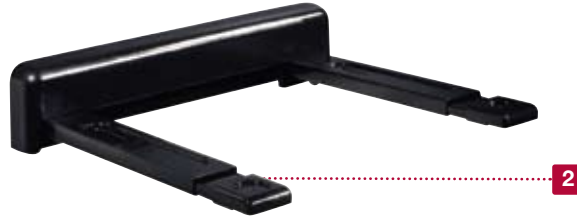

For expanded product information and technical data visit [www.peerlessmounts.com](http://www.peerlessmounts.com)

## TECHNICAL DRAWINGS

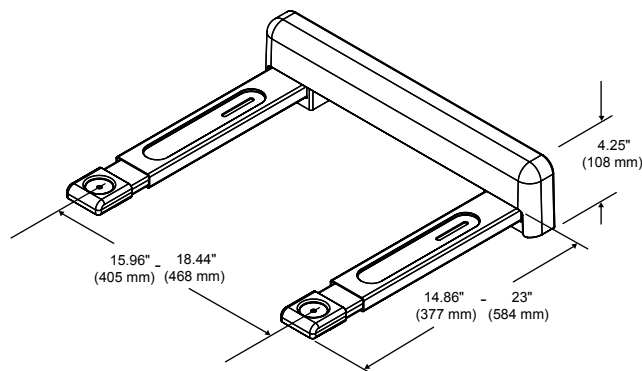

## MODELS

**PS200** Black

## SPECIFICATIONS



### Max load

100 lb (45 kg)

### Product Dimensions (W x H x D)

15.96"-18.44" x 4.25" x 14.86"- 23"  
(405-468 x 108 x 377-584 mm)

### Mounting Surfaces

Wood stud, concrete, cinder block and metal stud  
(Metal stud accessory required)

### Ship Weight

10.7 lb (4.8 kg)

## CERTIFICATIONS



## ACCESSORIES



**ACC215:**  
2-pack Metal Stud  
Fastener Kit .....pg# 126

To verify mount compatibility with any LCD, plasma or projector model use MountFinder™ at [www.peerlessmounts.com](http://www.peerlessmounts.com)



**CLICK:** [www.peerlessmounts.com](http://www.peerlessmounts.com)



**CALL:** 800.865.2112



**FAX:** 708.865.2941