

Corner Mount

For 32" to 58" Flat Panel Screens

1. Allows screen to fit in corner where space is limited
2. Includes SmartMount® SP850-UNL Pull-Out Swivel Mount
3. Expandable arms accommodate multiple screen sizes without having to adjust wall mount placement
4. SP850-UNL extends up to 10.75" (273 mm), pull-out swivel with up to 90° rotation; 0°, 5° or 10° lockable tilt
5. Wall units accommodate speakers when used with smaller screens (wall unit maybe visible with some smaller screens)
6. Optional shelf available for A/V components

Universal Models



For expanded product information and technical data visit www.peerlessmounts.com

TECHNICAL DRAWINGS

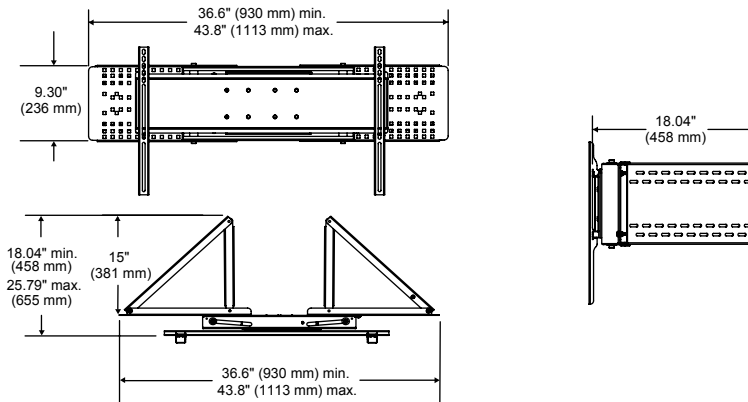

CM850(-S)

MODELS

Universal Kitted Models:

Includes SP850-UNL mount
Includes standard hardware (hex or Phillips) for attaching screen to mount

CM850 Black
CM850-S Silver

SCREEN ADAPTER



Mounting pattern

Universal Models: 28.7" W x 17.05" H
(729 x 433 mm)

SPECIFICATIONS



Distance from corner

18.04"–25.79" (458–655 mm)



Tilt | Swivel | Roll

0°, 5° or 10° | ±45° | ±1°



Max load

150 lb (68 kg)

Product Dimensions (W x H x D)

36.6"–43.8" x 9.30"
x 18.04"–25.79"
(930–1113 x 236 x 458–655 mm)

Mounting Surfaces

Wood stud, concrete
and cinder block

Ship Weight

Box 1: 30.5 lb (13.8 kg)
Box 2: 39 lb (17.7 kg)

CERTIFICATIONS



ACCESSORIES

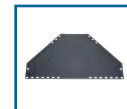

ACC324(-S):
Corner Mount Shelf pg# 131



ACC930:
Fastener Kit
for Speaker Mounts pg# 132

To verify mount compatibility with any LCD, plasma or projector model use MountFinder™ at www.peerlessmounts.com



CLICK: www.peerlessmounts.com



CALL: 800.865.2112



FAX: 708.865.2941