

LCD Ceiling Mount

For 15" to 37" LCD Screens



FLAT PANEL MOUNTS

1. VESA® 75, 100, 200 x 100 and 200 x 200 mm compliant
2. Three adjustable extension lengths:
PC932A models - 9.8" - 13.9" (249-353 mm)
PC932B models - 13.78" - 21.89" (350-556 mm)
PC932C models - 20.24" - 34.02" (514-864 mm)
3. Continuous tilt of +15/-5° with optional lock in 5° increments
4. Swivel adjustment within ceiling plate for screen placement opportunities
5. Internal cable management within extension channels for clean, clutter-free appearance
6. Safety catch designed into extension channels to ensure user and equipment safety



MODELS

Universal Models:

Includes theft resistant hardware for attaching screen to mount

With 9.8"-13.9" (249-353 mm) extension:

PC932A Black
PC932A-S Silver
PC932A-W White

With 13.78"-21.89" (350-556 mm) extension:

PC932B Black
PC932B-S Silver
PC932B-W White

With 20.24"-34.02" (514-864 mm) extension:

PC932C Black
PC932C-S Silver
PC932C-W White

SCREEN ADAPTER



VESA® pattern

Universal Models: 75, 100, 200 x 100 and 200 x 200 mm

SPECIFICATIONS

Distance from ceiling	
PC932A(-S)(-W)	9.8"-13.9" (249-353 mm)
PC932B(-S)(-W)	13.78"-21.89" (350-556 mm)
PC932C(-S)(-W)	20.24"-34.02" (514-864 mm)

Tilt Swivel	
	+15/-5° 360°

Max load	
	80 lb (36 kg)

Product Dimensions	(W x H x D)
PC932A(-S)(-W)	6.5" x 9.8"-13.9" x 6.5" (165 x 249-353 x 165 mm)
PC932B(-S)(-W)	6.5" x 13.78"-21.89" x 6.5" (165 x 350-556 x 165 mm)
PC932C(-S)(-W)	6.5" x 20.24"-34.02" x 6.5" (165 x 514-864 x 165 mm)

Mounting Surfaces	
	Wood joist, concrete and truss

Ship Weight	
PC932A(-S)(-W)	6.1 lb (2.76 kg)
PC932B(-S)(-W)	6.7 lb (3.04 kg)
PC932C(-S)(-W)	7.6 lb (3.44 kg)

For expanded product information and technical data visit www.peerlessmounts.com

TECHNICAL DRAWINGS

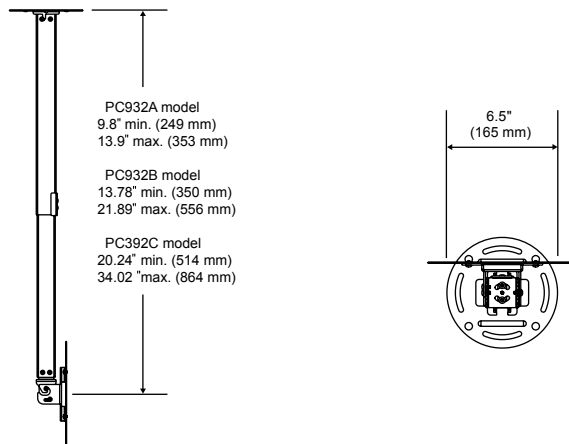

To verify mount compatibility with any LCD, plasma or projector model use MountFinder™ at www.peerlessmounts.com

CLICK: www.peerlessmounts.com

CALL: 800.865.2112

FAX: 708.865.2941

CERTIFICATIONS



ACCESSORIES



ACC575(-S)(-W):
Threaded Connector
Accessorypg# 128