



Flat Panel Stand

For 32" to 60" LCD and Plasma Screens

MODELS

Dedicated Models:

Screen adapter purchased separately for non-VESA® screens*
Includes theft resistant hardware for attaching screen to mount

FPZ-600 Black

* Dedicated adapter plates come in flat black and include security fasteners

SCREEN ADAPTER



VESA® pattern

Dedicated Models: 100, 200 x 100 and 200 x 200 mm
Non-VESA® compatible screens require screen-specific adapter to be purchased separately

SPECIFICATIONS

Height Adjustment

On 72" poles (1829 mm)

Max load

200 lb (90 kg) per screen up to four screens

Product Dimensions (W x H x D)

28.75" x 72" x 36"
(730 x 1829 x 914 mm)

Mounting Surfaces

All floor surfaces

Ship Weight

Box 1: 118 lb (53.5 kg)
Box 2: 17.6 lb (7.9 kg)
Box 3: 17.6 lb (7.9 kg)

CERTIFICATIONS



ACCESSORIES



ACC604:
Dual-Screen Cartridgepg# 130

1. VESA® 100, 200 x 100 and 200 x 200 mm compliant
2. Supports non-VESA® screens with additional PLP screen adapter (sold separately)
3. Fits single or back-to-back 32" to 60" flat panel screens (up to four with additional dual-screen cartridge)
4. Portrait or landscape orientation
5. Internal cable management for a clean, clutter-free appearance
6. Height adjustable on 72" (1829 mm) poles



TECHNICAL DRAWINGS

For expanded product information and technical data visit www.peerlessmounts.com

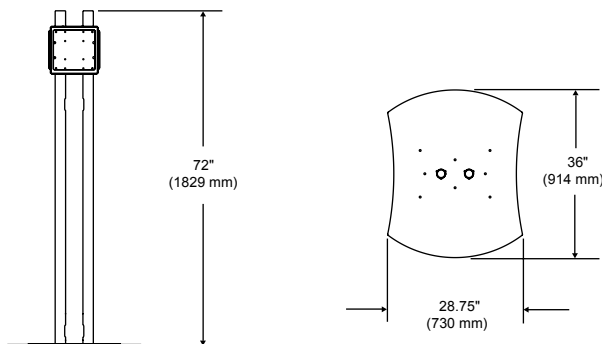

To verify mount compatibility with any LCD, plasma or projector model use MountFinder™ at www.peerlessmounts.com



CLICK: www.peerlessmounts.com



CALL: 800.865.2112



FAX: 708.865.2941