

Flat Panel Stand

For 50" to 71" Flat Panel Screens

1. VESA® 100, 200 x 100 and 200 x 200 mm compliant
2. Supports non-VESA® screens with additional PLP screen adapter (sold separately)
3. Internal cable management to easily route cords from the screen to the base of the stand
4. Base cover is designed to conceal content drivers and surge protector
5. Vertical adjustment on 6' (1829 mm) poles for ideal screen viewing height
6. Hook-on design allows screen to rest in place while screen is being secured
7. Portrait or landscape orientation



FLAT PANEL MOUNTS

MODELS

Dedicated Models:

Screen adapter purchased separately for non-VESA® screens*
Includes theft resistant hardware for attaching screen to mount
FPZ-670 Black

* Dedicated adapter plates come in flat black and include security fasteners

SCREEN ADAPTER



VESA® pattern

Dedicated Models: 100, 200 x 100 and 200 x 200 mm

Non-VESA® compatible screens require screen-specific adapter to be purchased separately

SPECIFICATIONS



Height Adjustment

On 6' poles (1829 mm)



Max load

200 lb (90 kg) per screen up to two screens

Product Dimensions (W x H x D)

39.87" x 72.3" x 48"
(1013 x 1836 x 1219 mm)

Mounting Surfaces

All floor surfaces



Ship Weight

Box 1: 165 lb (74.8 kg)
Box 2: 17.6 lb (7.9 kg)
Box 3: 17.6 lb (7.9 kg)

For expanded product information and technical data visit www.peerlessmounts.com

TECHNICAL DRAWINGS

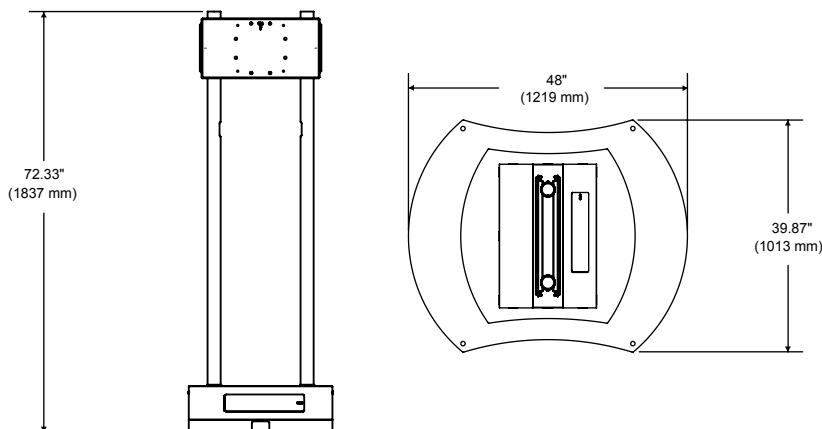

To verify mount compatibility with any LCD, plasma or projector model use MountFinder™ at www.peerlessmounts.com



CLICK: www.peerlessmounts.com



CALL: 800.865.2112



FAX: 708.865.2941