

Jumbo® Wide Body Carts

For Projectors and TVs up to 32" and A/V Equipment

MODELS

JCTWB44	Black
JCTWB44E	Black

SPECIFICATIONS

 Max load	300lb (136kg)
Product Dimensions (W x H x D)	32" x 43.6" x 27" (813 x 1108 x 686mm)
Ship Weight	
JCTWB44:	62lb (28.1kg)
JCTWB44E:	64.3lb (29.1kg)

CERTIFICATIONS



ACCESSORIES



ACC666:
Safety Belt.....pg# 160

1. Pyramid tip-resistant design
2. Multi-purpose cart for projectors, TVs or A/V equipment
3. Cable access hole in top and middle shelves for cable management
4. Hard rubber ball bearing casters allow for easy movement over dissimilar floor surfaces
5. Swivel casters include locking brake for stability
6. JCTWB44E includes 3-outlet electric strip & cord wrap bracket



TECHNICAL DRAWINGS

For expanded product information and technical data visit www.peerlessmounts.com

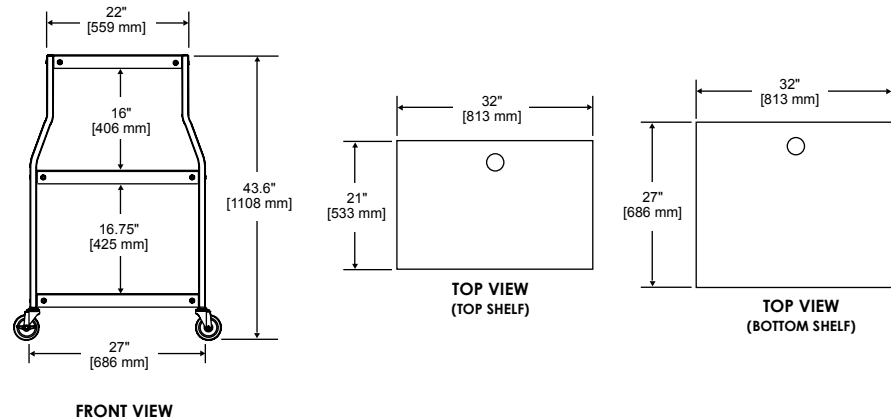

To verify mount compatibility with any LCD, plasma or projector model use MountFinder™ at www.peerlessmounts.com



CLICK: www.peerlessmounts.com



CALL: 800.865.2112



FAX: 708.865.2941

Adjustable Height Multi-purpose Carts

For Projectors and TVs up to 20" and A/V Equipment



1. JCT-P1642E
four adjustable heights:
16" (406mm)
26" (660mm)
34" (864mm)
42" (1067mm)
2. JCT-2642E
five adjustable heights:
26" (660mm)
30" (762mm)
34" (864mm)
38" (965mm)
42" (1067mm)
3. UL-approved 3-outlet electric strip with 15 ft (4.5m) line cord and cord wrap bracket
4. Hard rubber ball bearing casters allow for easy movement over dissimilar floor surfaces
5. Swivel casters include locking brake for stability



JCT-P1642E



JCT-2642E

MODELS

JCT-P1642E	Black
JCT-2642E	Black

SPECIFICATIONS



Max load

JCT-P1642E:	200lb (90kg)
JCT-2642E:	50lb (22kg)

Product Dimensions (W x H x D)

24" x 26"-42" x 18"
(610 x 660-1067 x 457mm)

Ship Weight

JCT-P1642E:	30lb (13.6kg)
JCT-2642E:	44lb (19.9kg)

CERTIFICATIONS



ACCESSORIES



ACC666:
Safety Belt.....pg# 160

For expanded product information and technical data visit www.peerlessmounts.com

TECHNICAL DRAWINGS

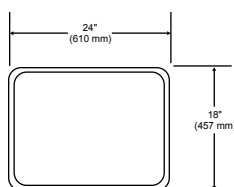

TOP VIEW

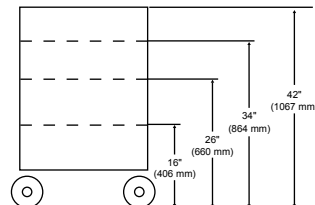

JCT-P1642E - FRONT VIEW

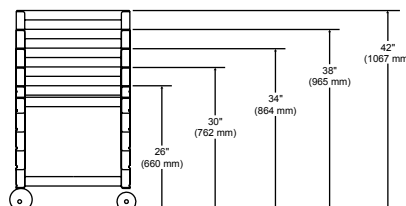

JCT-2642E - FRONT VIEW

To verify mount compatibility with any LCD, plasma or projector model use MountFinder™ at www.peerlessmounts.com



CLICK: www.peerlessmounts.com



CALL: 800.865.2112



FAX: 708.865.2941



Adjustable Height Multi-purpose Carts

For Projectors and TVs up to 32" and A/V Equipment

MODELS

JCT-P2642CE Black
JCT-P2854CE Black

SPECIFICATIONS

Max load	
JCT-P2642CE:	200lb (90kg)
JCT-2854CE:	300lb (136kg) 100lb (45kg) per shelf
Product Dimensions (W x H x D)	
JCT-P2642CE:	24" x 26"-42" x 18" (610 x 660-1067 x 457mm)
JCT-2854CE:	32" x 28"-54" x 24" (813 x 711-1372 x 610mm)
Ship Weight	
JCT-P2642CE:	46lb (20.87kg)
JCT-2854CE:	85.1lb (38.60kg)

CERTIFICATIONS



ACCESSORIES



ACC666:
Safety Belt.....pg# 160

- JCT-P2642CE for up to 20" TV's with adjustable height:
26" (660mm)
34" (867mm)
42" (1067mm)
- JCT-P2854CE for up to 32" TV's with adjustable height:
28" (711mm)
44" (1118mm)
48" (1219mm)
54" (1372mm)
- Includes locking storage cabinet with keys
- UL-approved 3-outlet electric strip with 15 ft (4.5m) line cord and cord wrap bracket
- Hard rubber ball bearing casters allow for easy movement over dissimilar floor surfaces
- Swivel casters include locking brake for stability



JCT-2854CE



JCT-P2642CE

TECHNICAL DRAWINGS

For expanded product information and technical data visit www.peerlessmounts.com

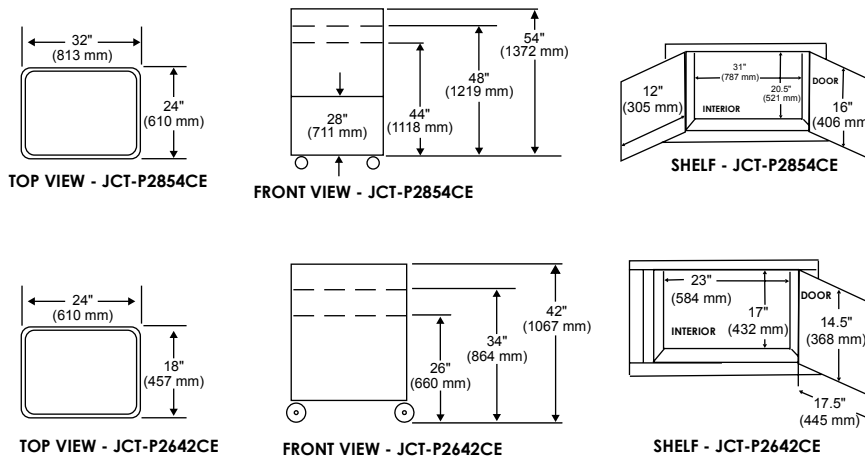

To verify mount compatibility with any LCD, plasma or projector model use MountFinder™ at www.peerlessmounts.com



CLICK: www.peerlessmounts.com



CALL: 800.865.2112



FAX: 708.865.2941