



# Two-link Articulating Desktop Pole

For 15" to 24" LCD Monitors

## MODELS

### Universal Models:

Includes standard hardware (hex or Phillips) for attaching screen to mount

<b>LCT-A1B3C</b>	Desk clamp	Silver
<b>LCT-A1B3H</b>	Bolt hole	Silver

## SCREEN ADAPTER

### VESA® pattern

Universal Models: 75 and 100mm

## SPECIFICATIONS

### Distance from base

up to 22.01" (559mm)

### Tilt | Swivel

Monitor tilt: +20°/-30°  
 Extension arm tilt: 0°/-90°  
 Swivel: 360°

### Max load

17.5lb (8kg)

### Product Dimensions (W x H x D)

<b>LCT-A1B3C:</b>	6.34" x 24.14" x 13.35"-22.01" (161 x 613 x 339-559mm)
<b>LCT-A1B3H:</b>	6.34" x 18.86" x 13.35"-22.01" (161 x 479 x 339-559mm)

### Mounting Surfaces

Desktop

### Ship Weight

<b>LCT-A1B3C:</b>	13.2lb (6kg)
<b>LCT-A1B3H:</b>	10.1lb (4.6kg)

1. VESA® 75 and 100mm compliant
2. 360° of lockable swivel
3. 14.4" (366mm) of height adjustment
4. Internal cable management
5. Portrait to landscape adjustment without removing the screen
6. Spring-loaded design
7. Desk clamp and desk bolt models available



## ACCESSORIES



**ACC918:**  
 Security Fasteners ..... pg# 156

## TECHNICAL DRAWINGS

For expanded product information and technical data visit [www.peerlessmounts.com](http://www.peerlessmounts.com)

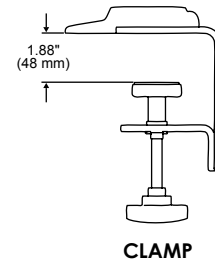
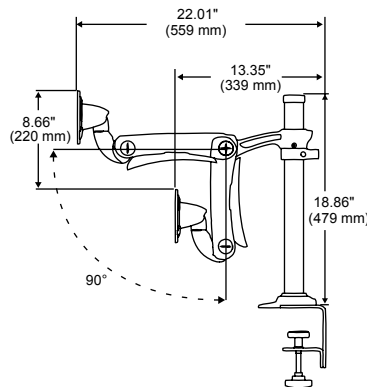

To verify mount compatibility with any LCD, plasma or projector model use MountFinder™ at [www.peerlessmounts.com](http://www.peerlessmounts.com)



CLICK: [www.peerlessmounts.com](http://www.peerlessmounts.com)



CALL: 800.865.2112



FAX: 800.359.6500