



PAG Gear Projector Mount

For Projectors up to 50 lb (22 kg)

MODELS

Universal Models:

Includes theft resistant hardware for attaching projector to mount
PAG-UNV Black

SCREEN ADAPTER

Mounting pattern

Universal Models: Up to 17.63" (448 mm)

SPECIFICATIONS

Tilt | Swivel | Roll

±25° | 360° | ±25°

Max load

50 lb (22 kg)

Product Dimensions (W x H x D)

8.5"-17.63" x 4.5"-7.14" x
 8.5"-17.63"
 (216-448 x 114-181 x 216-448 mm)

Mounting Surfaces

Wood joist, concrete
 and other structures
 (Other structures require accessory)

Ship Weight

5 lb (2.27 kg)

CERTIFICATIONS



ACCESSORIES



AEC, EXT Models:
 Extension Columns pg# 127

1. Spider® Universal Adapter Plate extends up to 17.63" (488 mm) to fit most projector models
2. Patented gear technology enables effortless adjustment to achieve precise image alignment
3. No tools required for image alignment, dual knob design provides hassle-free method for adjusting the gears
4. Cable management system allows for cable routing straight through the mount to keep the projector cables secure and out of sight
5. Quick-release mechanism to easily service projector
6. Delivers precise image alignment:

Tilt: ±25°
 Swivel: 360°
 Roll: ±25°



TECHNICAL DRAWINGS

For expanded product information and technical data visit www.peerlessmounts.com

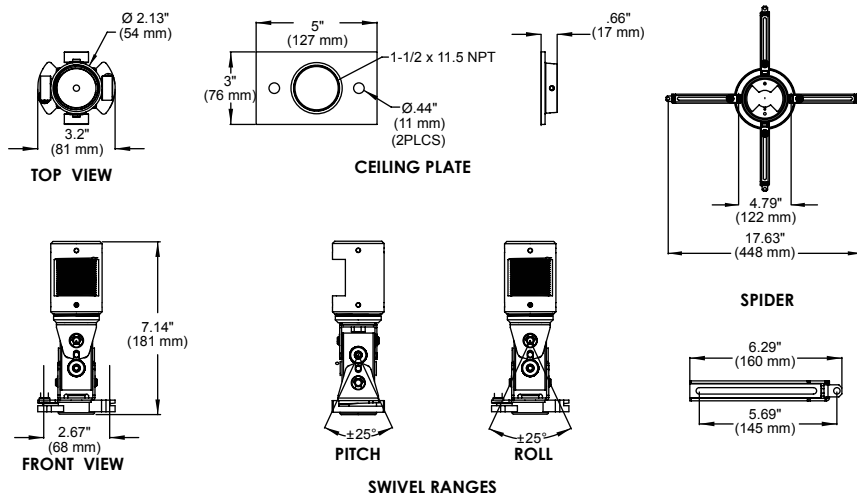

To verify mount compatibility with any LCD, plasma or projector model use MountFinder™ at www.peerlessmounts.com



CLICK: www.peerlessmounts.com



CALL: 800.865.2112



FAX: 708.865.2941