



Swivel and Tilt Wall Mount

For 32" to 71" Flat Panel Screens

MODELS

Dedicated Models:

Includes theft resistant hardware for attaching screen to mount
Screen adapter purchased separately*



- PS-1** Black for 32" to 50" screens
- PS-2** Black for 42" to 71" screens

* Dedicated adapter plates come in flat black and include security fasteners

SCREEN ADAPTER

Dedicated Models: Require screen-specific PLP adapter to be purchased separately

SPECIFICATIONS

	Distance from wall
	PS-1: 8.75" (222 mm) PS-2: 10.12" (257 mm)
	Tilt Swivel
	+10°/-5° ±15°
	Max load
	PS-1: 150 lb (68 kg) PS-2: 225 lb (102 kg)
	Product Dimensions (W x H x D)
	PS-1: 22" x 12.08" x 8.75" (559 x 306 x 222 mm)
	PS-2: 22" x 12.04" x 10.12" (559 x 305 x 257 mm)
	Mounting Surfaces
	Wood stud, concrete and cinder block
	Ship Weight
	PS-1: 24 lb (11 kg) PS-2: 26.5 lb (12 kg)

1. 15° swivel from left to right
2. Offers 10° of forward tilt and 5° of backward tilt
3. Mount enables leveling adjustment of flat panel to sit level at any angle; no tools required
4. Screen mounts in landscape or portrait orientation
5. PS-1 arm holds screen 8.75" (222 mm)
6. PS-2 arm holds screen 10.12" (257 mm)



TECHNICAL DRAWINGS

For expanded product information and technical data visit www.peerlessmounts.com

CERTIFICATIONS

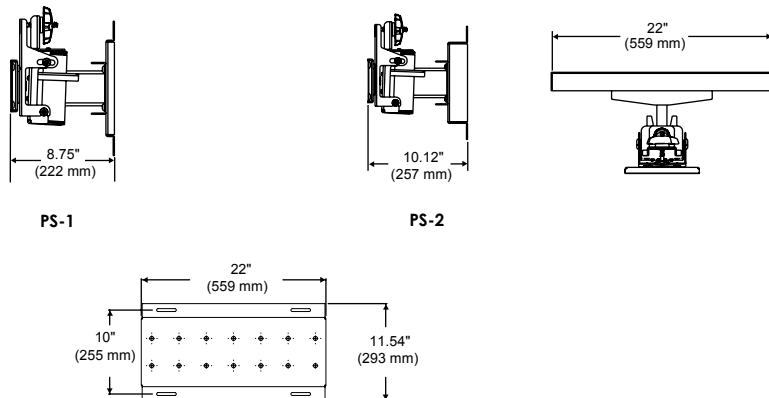

To verify mount compatibility with any LCD, plasma or projector model use MountFinder™ at www.peerlessmounts.com



CLICK: www.peerlessmounts.com



CALL: 800.865.2112



FAX: 708.865.2941