

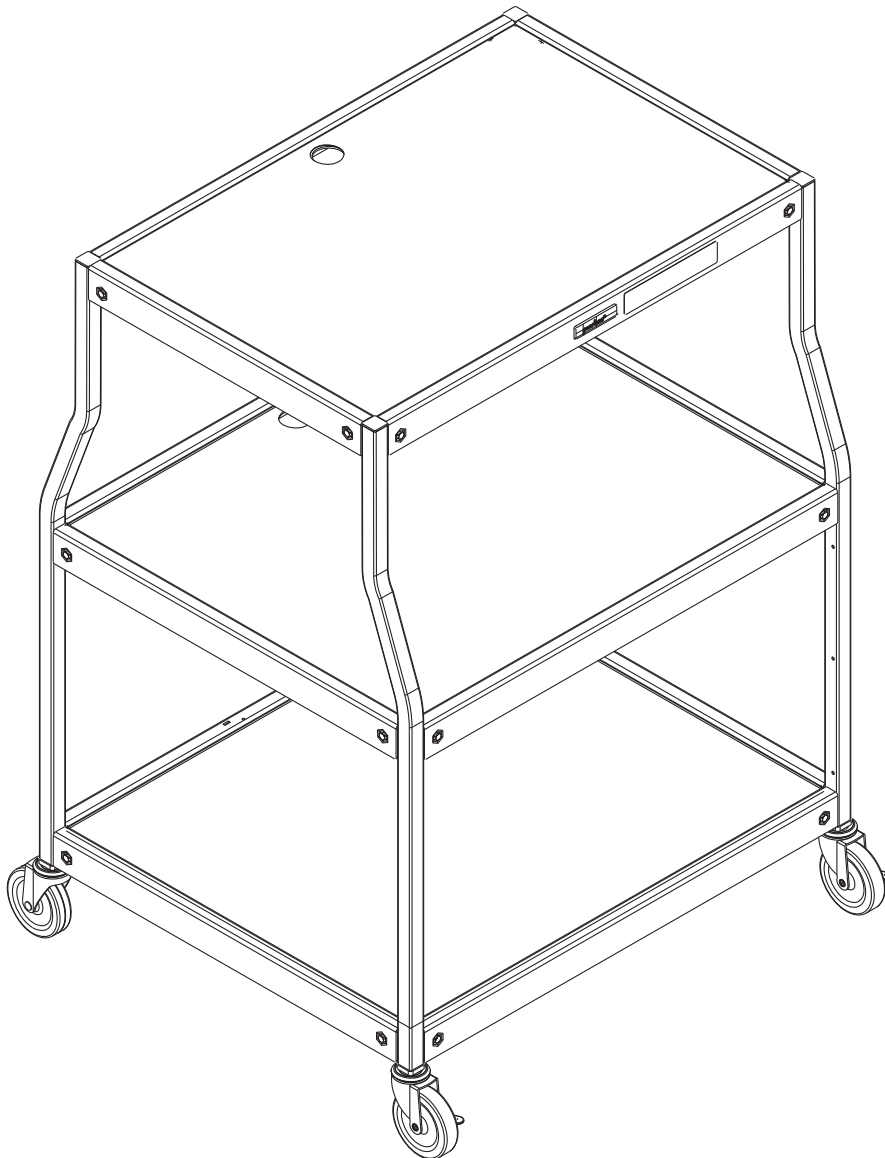

Installation and Assembly: Wide Base Cart

Models: JCT-WB44, JCT-WB44E



Note: Read entire instruction sheet before you start installation and assembly.

⚠ WARNING

- Do not begin to install your Peerless product until you have read and understood the instructions and warnings contained in this Installation Sheet. If you have any questions regarding any of the instructions or warnings, please call Peerless customer service at 1-800-729-0307.
- This product should only be installed by a qualified professional.
- Unit should be moved by authorized adults only.
- Prior to moving tables, place all AV equipment materials on lowest shelf possible. Secure heavy or bulky equipment to table with safety belts.
- Disconnect all electrical cords from wall outlets and secure to equipment on table.
- Unlock all casters, push mobile table from the narrow side of unit only. Never pull.
- Avoid rough or uneven flooring and remove any obstacles in your path.
- Apply force to the narrow side. Do not pull the unit.
- When set up for stationary use or when loading or unloading equipment, books, etc., always secure the casters before doing so.
- When using the table as an equipment stand, the equipment should be put on the lowest possible shelf that will still allow the equipment to operate correctly. The equipment should be placed in the center of the shelf it is sitting on.
- The product should not be used as a stool or a ladder.

Parts List

Description	Qty.	Part #
A top shelf (displays Peerless logo)	1	009-1049
B middle shelf	1	009-1035
C bottom shelf	1	009-1034
D legs	4	009-1041
E carriage bolt	24	520-1220
G serrated flanged hex nut	24	530-1048
H 4" casters without brakes (not shown)	2	560-0082
I 4" casters with brakes (not shown)	2	560-0083
J Cord Wrap - Clip (JCT WB44E only)	1	009-1168
K 15' Extension Cord (JCT WB44E only)	1	600-1011
L phillips screw (JCT WB44E only)	2	520-1219
M wingnut (JCT WB44E only)	2	530-1025
N rubber mat	1	009-1167

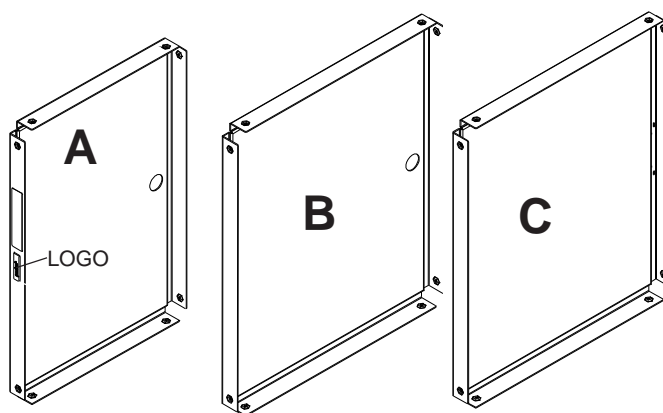

Some parts may appear slightly different than illustrated.

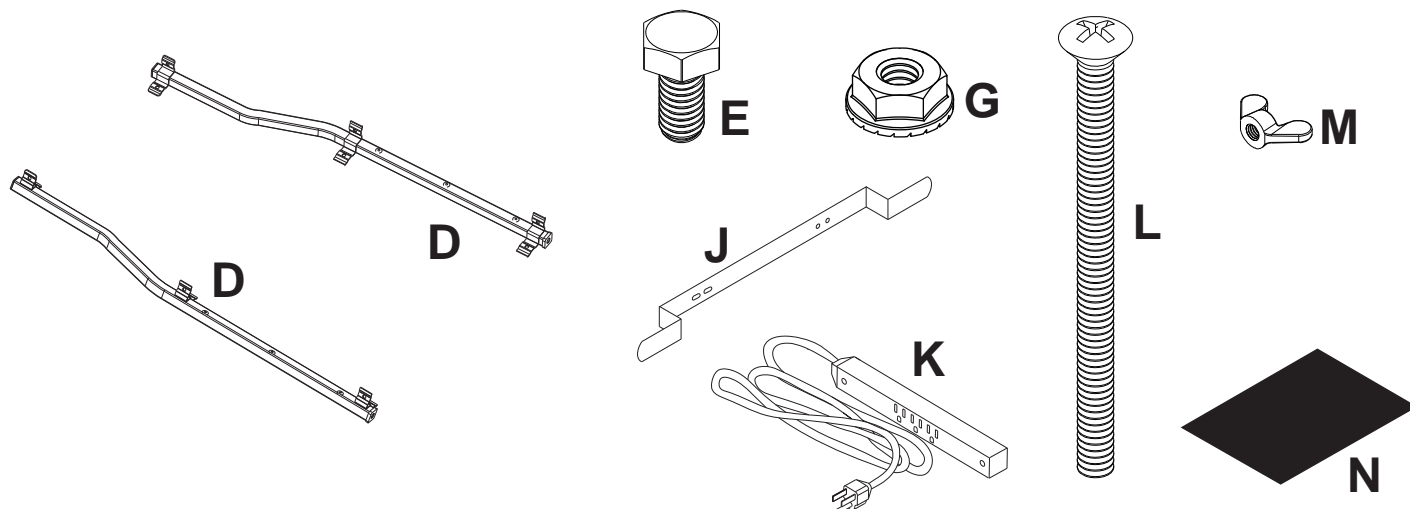

- 1 Lay front legs (D) on the floor with the brackets facing upward and inward as illustrated.

NOTE: Remove adhesive foam from brackets on legs to uncover holes.

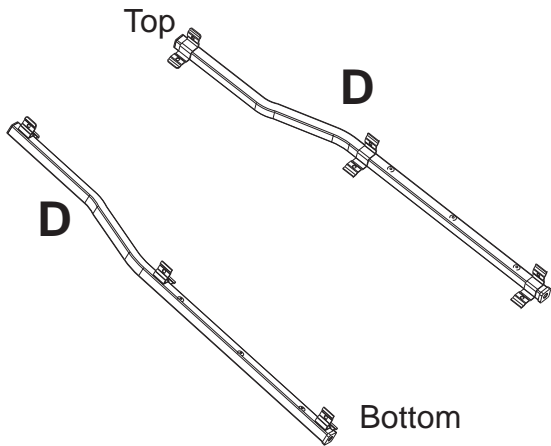

- 2 Slide each shelf over the brackets of the legs (D). The smallest shelf (A) is the top. The cord management holes of top shelf (A) and middle shelf (B) align in the back.

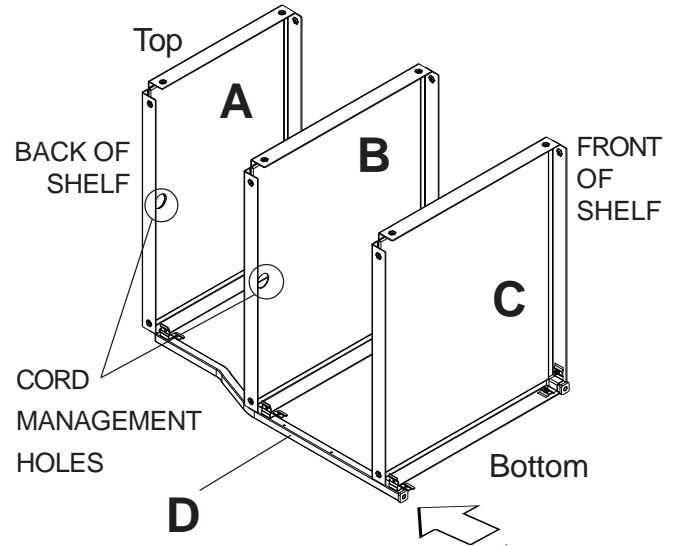

- 3 Slide two remaining legs (D) onto the shelves as illustrated. Make sure that the brackets are inside the shelves. As shown in figure 3.1.

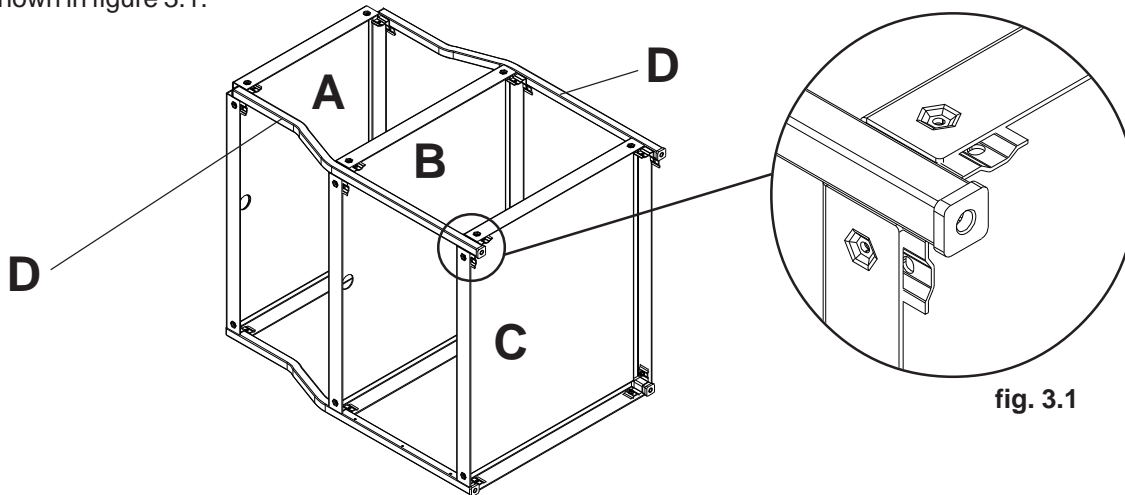

- 4 Secure all shelves to the legs with supplied hex screw (E) and serrated flanged hex nut (G) as illustrated. Serrated flanged hex nuts should be on the inside of the unit.

ONLY HAND TIGHTEN SCREWS AND NUTS AT THIS TIME.

NOTE: It is very important that the next step be preformed on a level surface in order to have the unit properly aligned. Stand unit upright on a level surface. Gently rock unit back and forth to realign and level the unit. **TIGHTEN ALL NUTS (G) AND SCREWS (E) WITH WRENCHES AT THIS TIME.** Unit should now be properly aligned and level. If unit is not level at this time, repeat this step before proceeding to step 5.

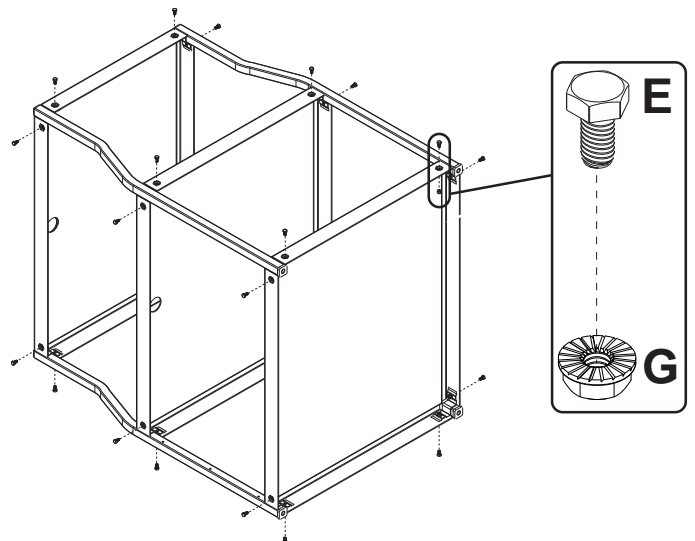

- 5 Lay unit on its back (logo on top shelf (A) should be facing up) and insert casters with brakes (I) into the front holes in the bottom of the cart. Insert the other casters (H) into the back holes of cart.

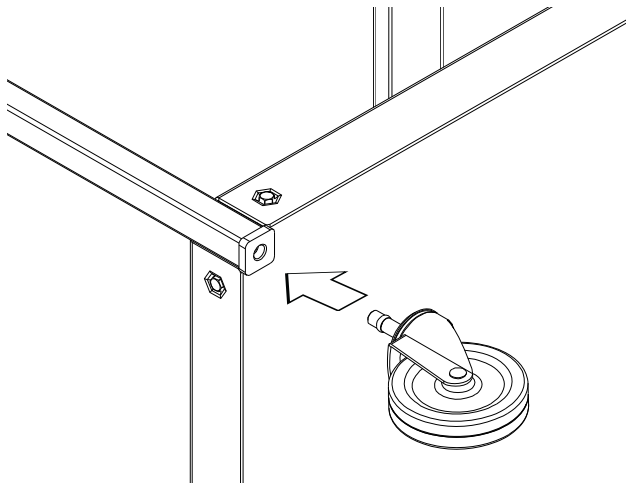

- 6 Stand unit onto casters and lay rubber mat (N) onto top shelf. Ribbed side of mat should be upward.

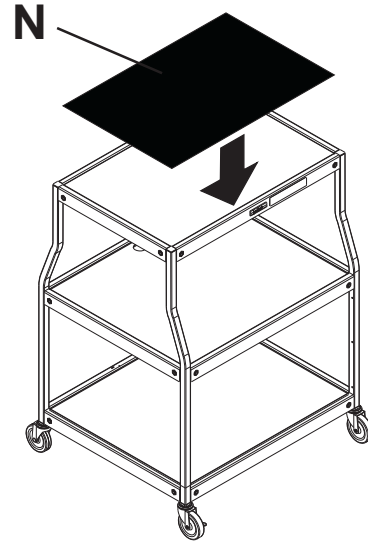

This Step is for model JCT WB44E only!

- 7 Fasten cord wrap clip (J) and extension cord (K) to desired top shelf (A) using two phillips screws (L) and two wing nuts (M) as shown.

Wrap extension cord around cord clip.

