

Installation and Assembly: Metal Overhead Cart

Model: JCT-MOC29E

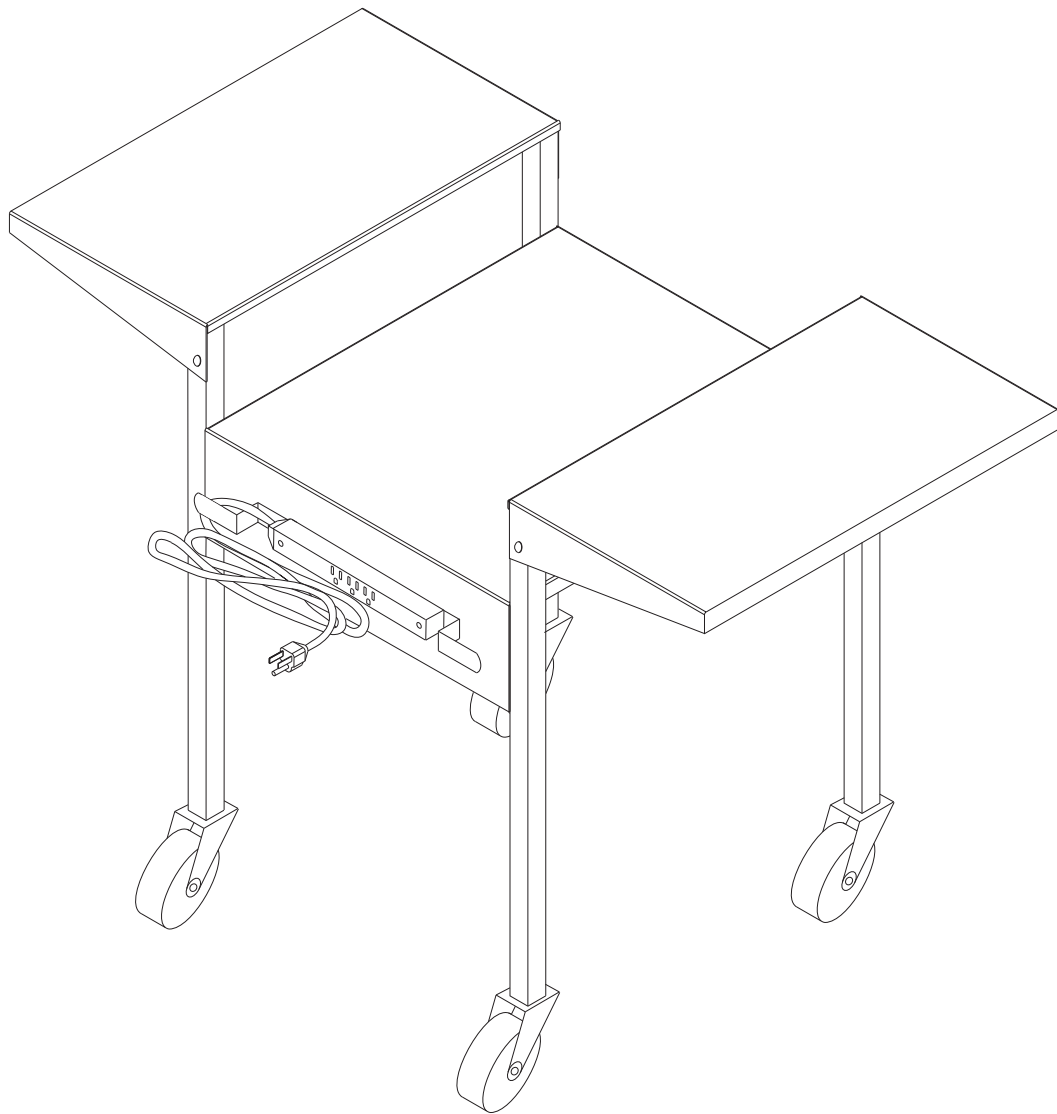

Max Load Capacity: 125 lb (56.7 kg)

Note: Read entire instruction sheet before you start installation and assembly.

▲ WARNING

- Do not begin to install your Peerless product until you have read and understood the instructions and warnings contained in this Installation Sheet. If you have any questions regarding any of the instructions or warnings, please call Peerless customer service at 1-800-729-0307.
- This product should only be installed by a qualified professional.
- Unit should be moved by authorized adults only.
- Prior to moving tables, place all AV equipment materials on lowest shelf possible. Secure heavy or bulky equipment to table with safety belts.
- Disconnect all electrical cords from wall outlets and secure equipment on table.
- Unlock all casters, push mobile table from the narrow side of unit only. Never pull.
- Avoid rough or uneven flooring and remove any obstacles in your path.
- Apply force to the narrow side. Do not pull the unit.
- When set up for stationary use or when loading or unloading equipment, books, etc., always secure the casters before doing so.
- When using the table as an equipment stand, the equipment should be put on the lowest possible shelf that will still allow the equipment to operate correctly. The equipment should be placed in the center of the shelf it is sitting on.
- The product should not be used as a stool or a ladder.

Tools Needed for Assembly

- Phillips head screwdriver
- Slotted screwdriver

JCT-MOC29E Parts List			
Description	Qty.	Part No.	
AA side support	2	009-1189	
BB shelf	1	009-1190	
CC welded extension strap and cord wrap	1	009-1168	
DD caster with brake (not shown)	2	560-0083	
EE caster	2	560-0082	
FF 15' extension cord with 3 outlet	1	600-1011	
GG shelf screw	8	520-1221	
HH soft bumper	8	590-1192	
II hard bumper	4	590-1193	
JJ adhesive friction pad	4	590-1194	
KK 1.5" screw	2	520-1219	
LL winged nut	2	530-1025	

Some parts may appear slightly different than illustrated.

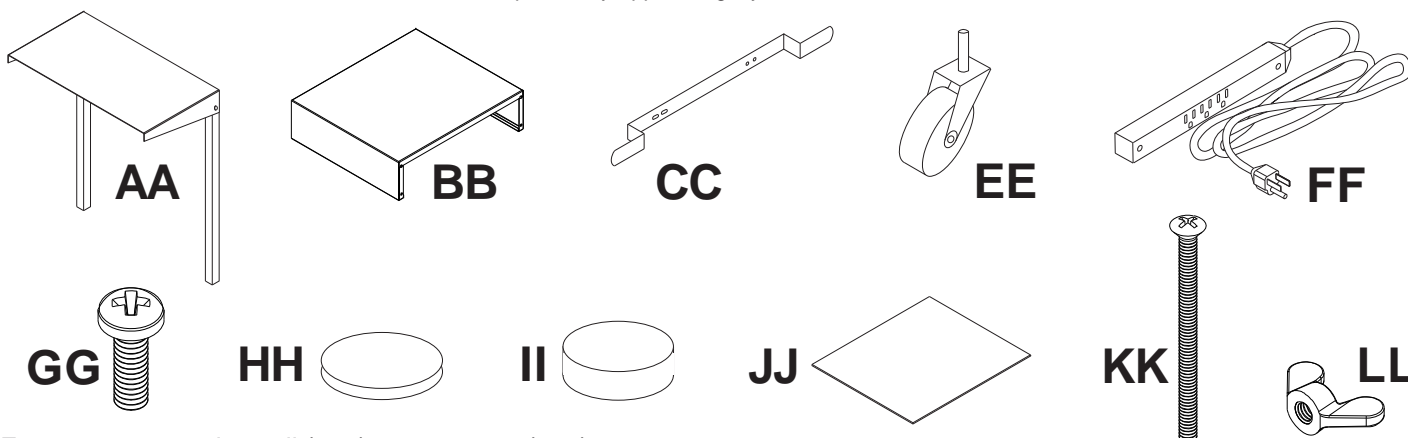

For customer service call (800) 729-0307 or (708) 865-8870.

- 1** Align corresponding holes of shelf (**BB**) with holes of side support (**AA**) using four shelf screws (**GG**) as shown. See table and illustration of detail 1 for corresponding holes to obtain desired height of table.

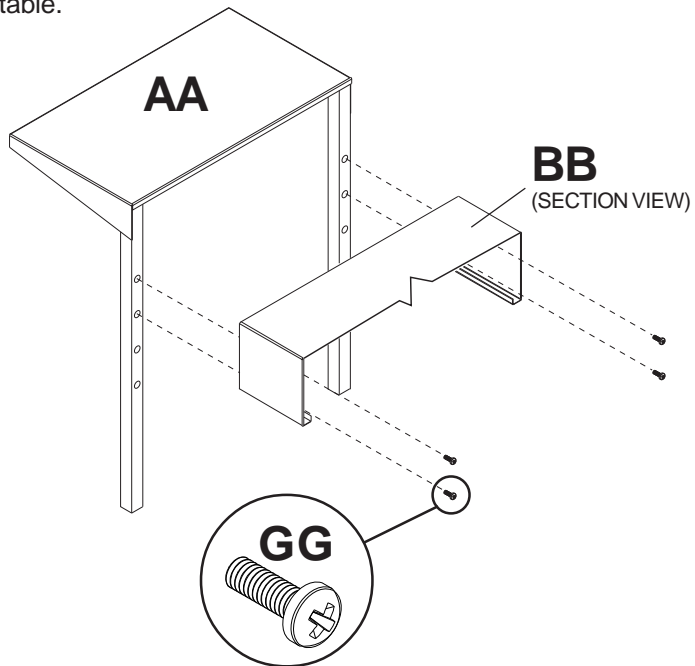

DETAIL 1

Unit Height	Corresponding Holes
23.5"	1 & 2
20.75"	2 & 3
18"	3 & 4

- 2** **Note:** Logo on the shelf indicates front of the cart. Lay unit upside down on floor. Insert caster with brakes (**DD**) into the front two holes in the bottom of the unit. Insert other casters (**EE**) into remaining holes of unit.

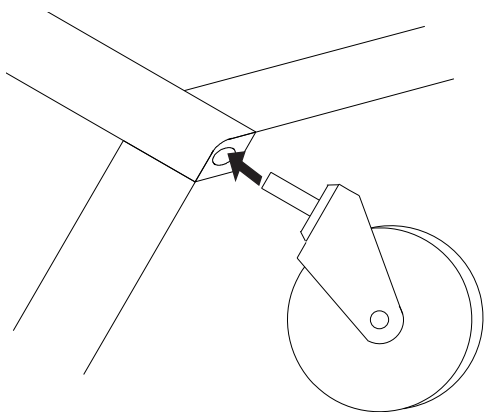

- 3** Fasten cord wrap (**CC**) and extension cord (**FF**) to shelf (**BB**) using two screws (**KK**) and two winged nuts (**LL**) as shown.

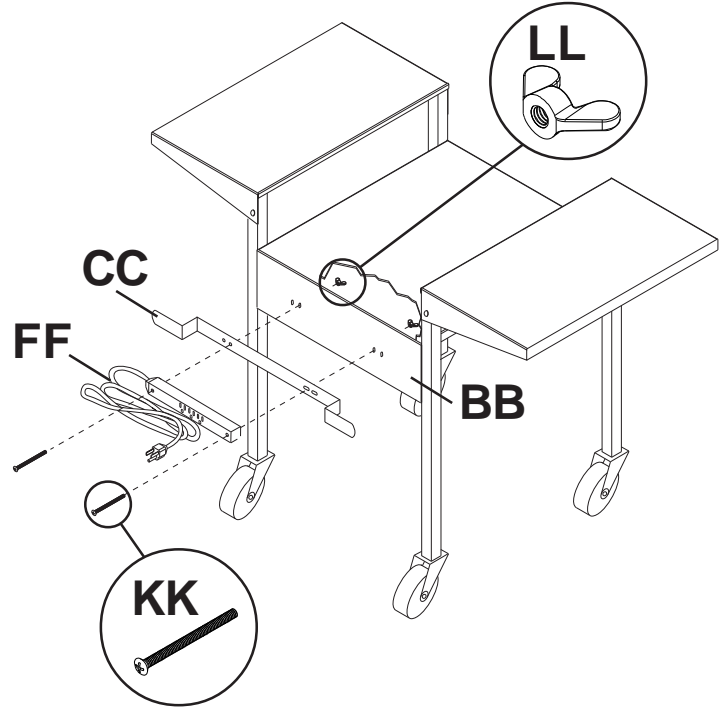

4 Position and adhere four friction pads (**JJ**) on top of shelf (**BB**). This helps to keep items from sliding on top of shelf.

Note: To prevent scratching of the surface, place soft bumpers (**HH**) or hard bumpers (**II**) underneath items placed upon shelf.

