

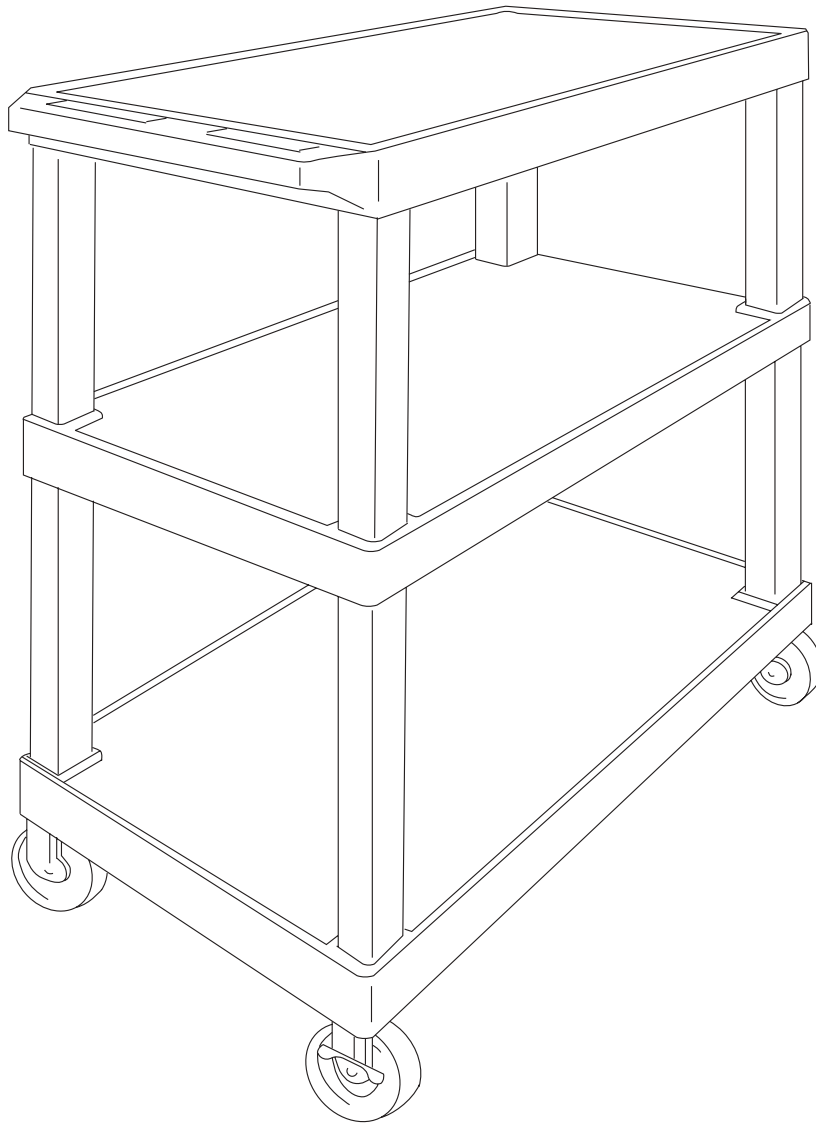

Installation and Assembly: Video and Utility Table

Model: JCT-P2854E, JCT-P2854CE



⚠ WARNING

- Do not begin to install your Peerless product until you have read and understood the instructions and warnings contained in this Installation Sheet. If you have any questions regarding any of the instructions or warnings, please call Peerless customer care at 1-800-729-0307.
- This product should only be installed by a qualified professional.
- Unit should be moved by authorized adults only.
- Prior to moving tables, place all AV equipment materials on lowest shelf possible. Secure heavy or bulky equipment to table with safety belts.
- Disconnect all electrical cords from wall outlets and secure to equipment on table.
- Unlock all casters, push mobile table from the narrow side of unit only. Never pull.
- Avoid rough or uneven flooring and remove any obstacles in your path.
- Apply force to the narrow side. Do not pull the unit.
- When set up for stationary use or when loading or unloading equipment, books, etc., always secure the casters before doing so.
- When using the table as an equipment stand, the equipment should be put on the lowest possible shelf that will still allow the equipment to operate correctly. The equipment should be placed in the center of the shelf it is sitting on.
- The product should not be used as a stool or a ladder.

Tools Needed for Assembly

- Rubber Mallet (NOT INCLUDED)

Parts List

Description	Qty.	Part #
A top shelf (with handle)	1	009-0193
B middle shelf (w/ 8 leg bosses)	1	009-0194
C bottom shelf (w/ caster inserts)	1	009-0195
D cable management clips (not shown)	3	590-0117
E 4" casters without brakes (not shown)	2	560-0082
F 4" casters with brakes (not shown)	2	560-0083
G friction pad	4	590-1194
H cord wrap clip	1	009-1168
I 15' extension cord	1	600-1011
J small phillips head bolts	2	520-1219
K wingnuts	2	530-1025
L 16 3/4" legs	4	009-0196
M 20 5/16" legs (JCT-P2854E only)	8	009-0198
N 20 5/16" legs (JCT-P2854CE only)	4	009-0198
O 25 5/16" legs	4	009-0197
P grooved legs (JCT-P2854CE only)	4	009-0199
Q back panel (JCT-P2854CE only)	1	009-0200
R side panel (JCT-P2854CE only)	2	009-0201
R door panel (JCT-P2854CE only)	1	009-0202

Some parts may appear slightly different than illustrated.

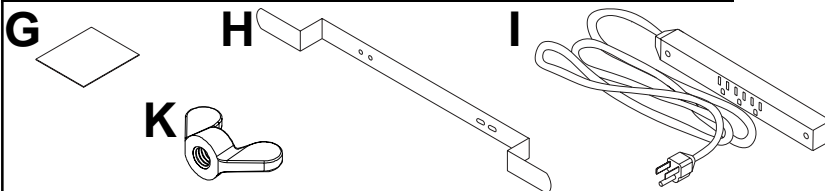
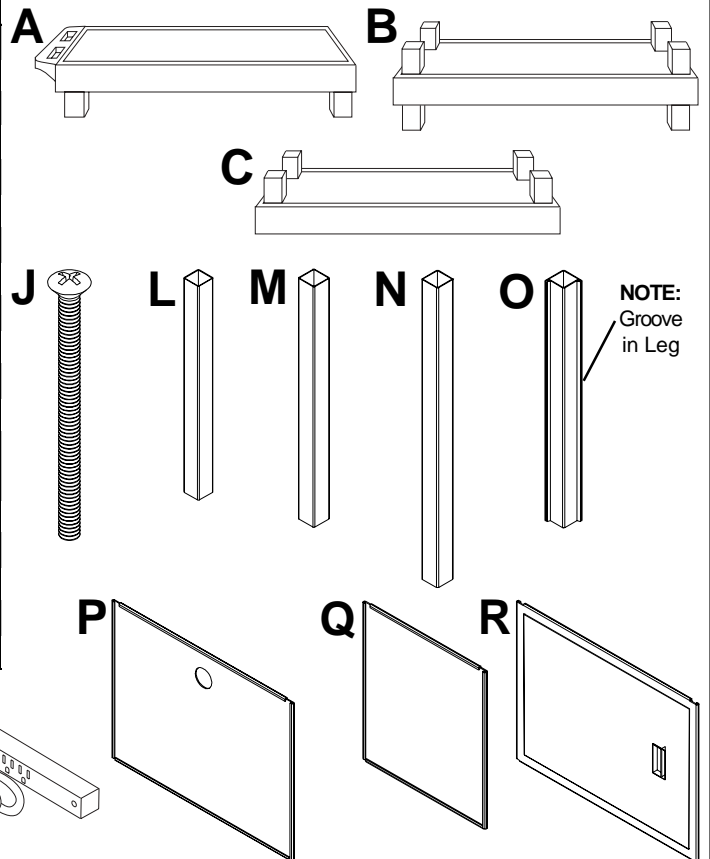

1 Separate legs by length. When assembling three shelf tables, the four legs between the bottom and middle shelves are 20 5/16" long.

Lay top shelf (A) face down on a flat, firm surface, preferably a non-carpeted concrete floor. By hand, firmly push the proper size legs that go between the top shelf and the middle shelf into place on leg bosses.

DESIRED UNIT HEIGHT	QTY	USE THESE LEGS
28"	4	20-5/16" (top and bottom shelves only) (JCT-P2854E uses legs "M") (JCT-P2854CE uses legs "O")
44"	4	20-5/16" (JCT-P2854CE uses legs "O")
	4	16 3/4"
48"	8	20-5/16" (JCT-P2854CE uses legs "M" & "O")
54"	4	20-5/16" (JCT-P2854CE uses legs "M" & "N")
	4	25-5/16"

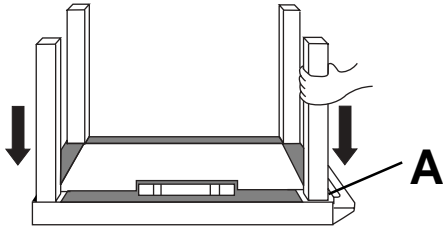

2 Use a rubber mallet (or optional metal hammer with wood block) to firmly seat legs into leg encapsulation cavities of the top shelf (A), rotating around table in stages to avoid damaging shelf or legs.

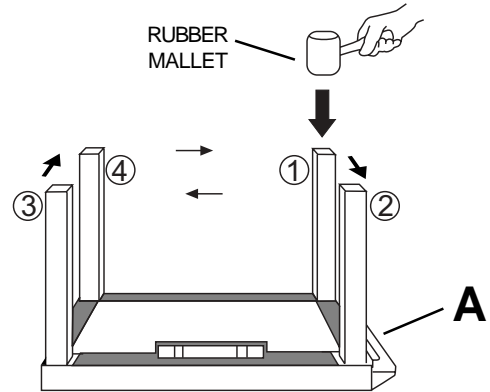

3 Set middle shelf (B) onto legs from the top shelf (A) and set legs onto the leg encapsulation cavities by hand.

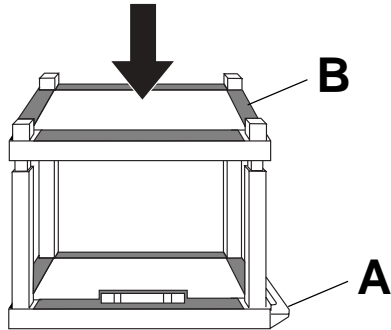

4 Use rubber mallet to firmly seat shelf (B) onto legs, rotating around the table in stages to avoid damaging shelf or legs.

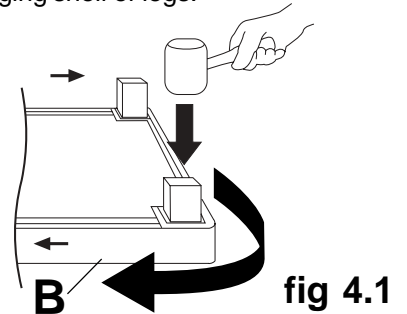

5 Now position legs that go between middle (B) and bottom (C) shelves into place by hand as shown in fig. 5.2. Use rubber mallet to firmly seat into shelf, rotating around the table in stages to avoid damage as shown in fig. 4.1.

NOTE: For model JCT-P2854CE, use four grooved legs (O) for this step. Notice groove orientation before positioning leg (O) in shelf (B) as shown in fig. 5.1.

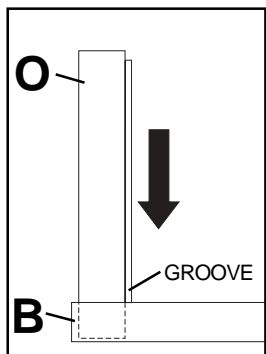

SIDE VIEW
fig 5.1

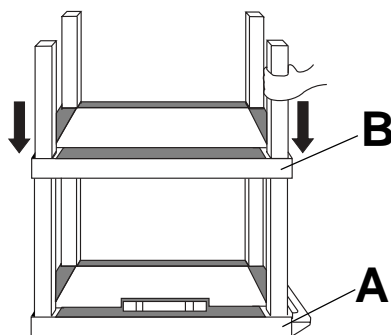
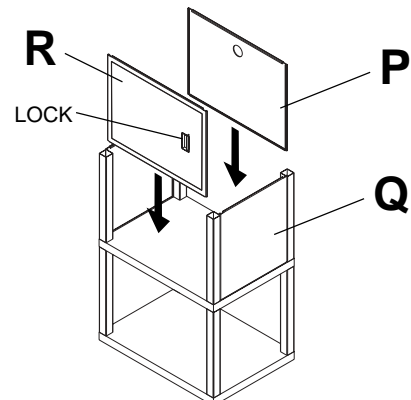

fig 5.2

STEP 6 IS FOR MODEL JCT-P2854CE ONLY!

6 Locate back panel (P) and slide down into grooves of two back legs. Take two side panels (Q) and slide into place. Take front panel (R) and slide into place with the lock positioned as shown.



7 Position bottom shelf leg bosses onto legs by hand. Then, using rubber mallet, proceed to firmly seat legs into encapsulation cavities of bottom shelf by rotating in stages around the table until all legs are fully seated as shown in detail 1.

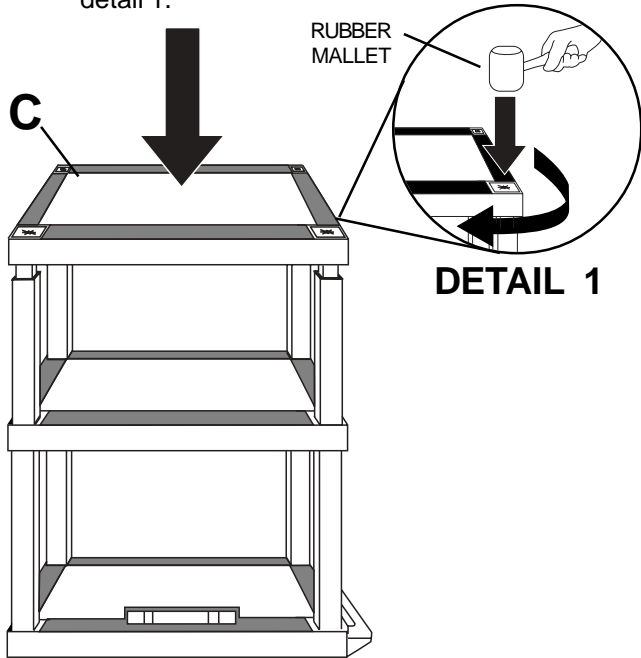

8 Pound casters into caster sockets on under side of bottom shelf with rubber mallet.

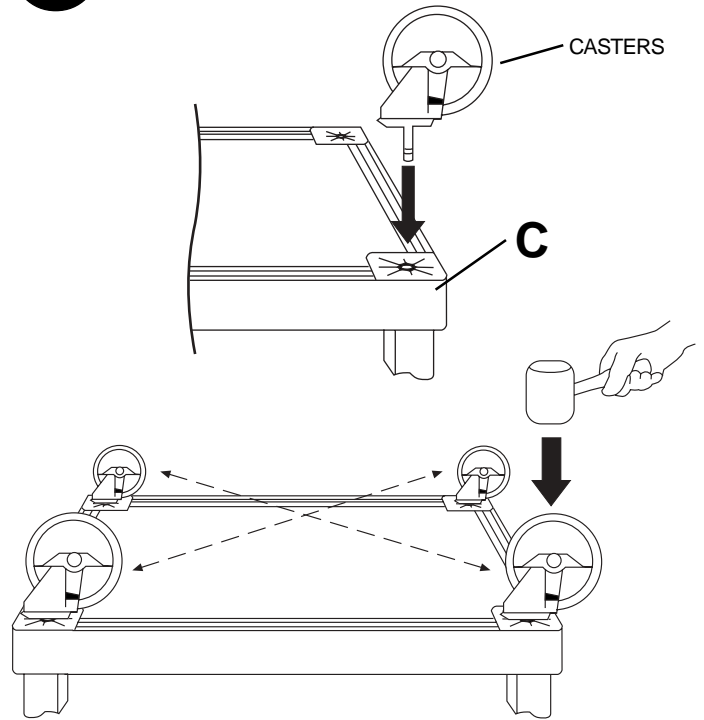

9 Fasten cord wrap clip (H) and extension cord (I) to top shelf using two screws (J) and two wing nuts (K) as shown.

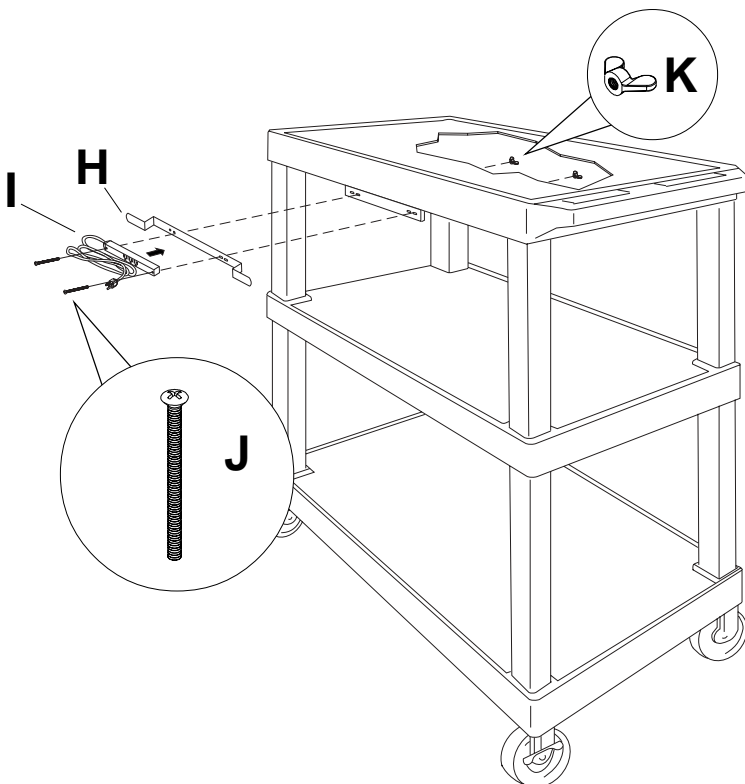

10 Position and adhere four friction pads (G) on top of shelf (A). This helps to keep items from sliding on top of shelf.

