

Installation and Assembly - Projector Adapter Plate for Panasonic® PT-LM1U Projector

Models: PAP 223,
PAP 223-S,
PAP 223-W

IMPORTANT! Read entire instruction sheet before you start installation and assembly.

Before you start check the parts list below to make sure all of the parts shown are included.

⚠ WARNING

- Installer must verify that the ceiling will safely support four times the combined weight of all attached equipment and hardware.

PARTS LIST

Description	Qty.	PAP 223	PAP 223-S	PAP 223-W
AA adapter plate	1	055-1455	055-4455	055-2455
BB M4 x 16 mm serrated washer head socket pin screw	2	510-1087	510-2087	510-2087
CC .313" OD x .375" H retaining spacer	2	590-2020	590-2009	590-2009
DD M4 x 20 mm thumb screw	1	560-1137	560-7137	560-7137
EE .313" OD x .5" H retaining spacer	1	590-2021	590-2017	590-2017
FF 4 mm security allen wrench (for PAP only)	1	560-9646	560-9646	560-9646

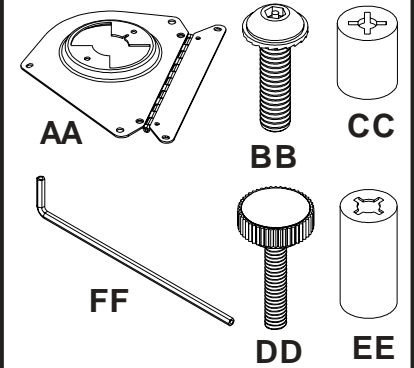

- 1 Flip projector upside down. Attach adapter plate (AA) to projector using two M4 x 16 mm screws (BB) and two .375" H retaining spacers (CC) as shown. Tighten screws using 4 mm security allen wrench (FF).

- 2 *Notch indicates front of projector. Close adapter plate (AA). Place .5" H retaining spacer (EE) between adapter plate (AA) and projector. Fasten with thumb screw (DD).

Retaining spacers (CC) go between adapter plate and projector.

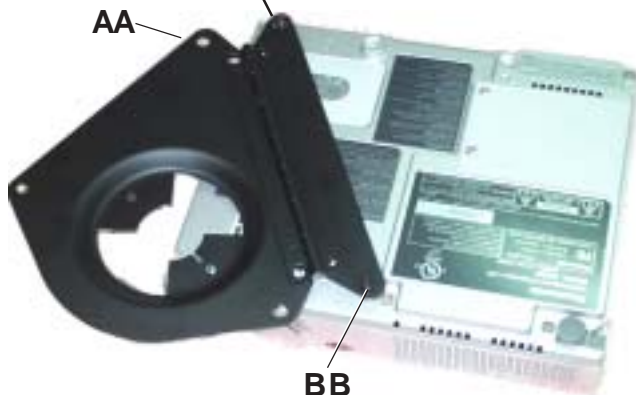
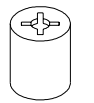

Retaining spacer (EE) goes between adapter plate and projector.

