

Installation and Assembly - Projector Adapter Plate for InFocus® LP540 Projector

Models: PAP 221,
PAP 221-S,
PAP 221-W

IMPORTANT! Read entire instruction sheet before you start installation and assembly.

Before you start check the parts list below to make sure all of the parts shown are included.

⚠ WARNING

- Installer must verify that the ceiling will safely support four times the combined weight of all attached equipment and hardware.

Parts List

Description	Qty.	PAP 221	PAP 221-S	PAP 221-W
AA adapter plate	1	055-1461	055-4461	055-2461
BB M4 x 16 mm serrated washer head socket pin screw	2	510-1087	510-2087	510-2087
CC M4 x 20 mm thumb screw	1	560-1137	560-7137	560-7137
DD .198 x .313 x .375" retaining spacer	2	590-2020	590-2009	590-2009
EE .198 x .313 x .500" retaining spacer	1	590-2021	590-2017	590-2017
FF 4 mm security allen wrench (for PAP only)	1	560-9646	560-9646	560-9646

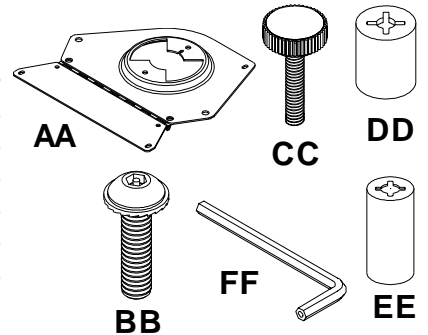

Note: Actual parts may appear slightly different than illustrated.

- 1** Flip projector upside down. Attach adapter plate (**AA**) to projector using two M4 x 16 mm screws (**BB**) and two retaining spacers (**DD**) as shown. Tighten screws using 4 mm security allen wrench (**FF**).

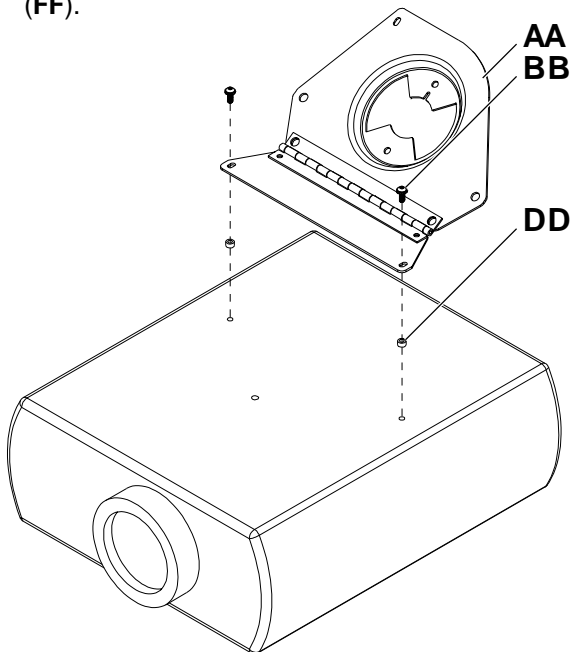

- 2** *Notch indicates front of projector. Close adapter plate (**AA**). Place retaining spacer (**EE**) between adapter plate (**AA**) and projector. Fasten with thumb screw (**CC**).

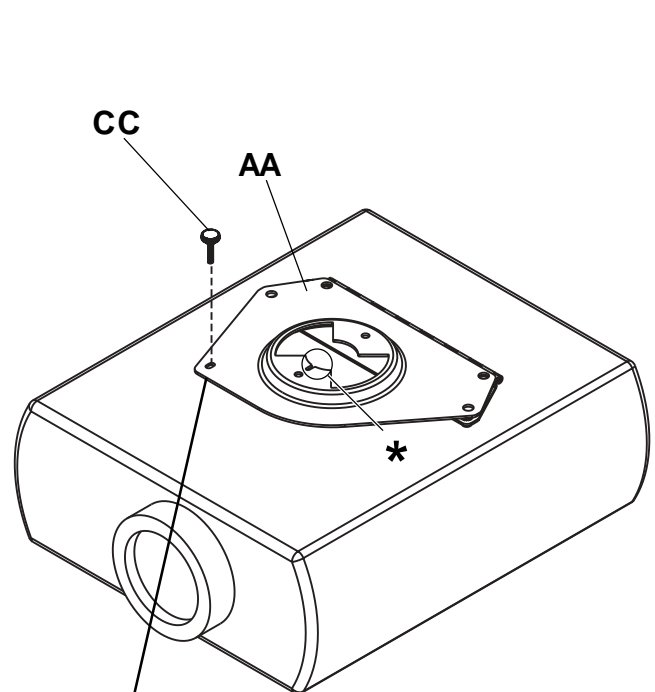

Retaining spacer (**EE**) goes between adapter plate (**AA**) and projector.

