

Installation and Assembly: Security Fasteners For Universal PLP Plates

Models: ACC925

*Before you begin, make sure all parts shown are included with your product.
Parts may appear slightly different than illustrated.*

Parts List

Description	Qty.	Part Number
A M8 x 15 mm socket pin screw	6	520-1068
B M8 x 40 mm socket pin screw	4	520-1152
C .5" ID x .5" H spacer	4	540-1057
D .75" OD x .5" H spacer	4	540-1059
E multi-washer	6	580-1036
F M6 x 20 mm socket pin screw	4	520-9554
G M6 x 30 mm socket pin screw	4	520-1067
H M8 x 25 mm socket pin button screw	4	520-1101
I M4 x 12 mm socket pin serrated washer head screw	6	510-1079
J M4 x 25 mm socket pin serrated washer head screw	4	510-1082
K M5 x 12 mm socket pin screw	4	520-1064
L M5 x 25 mm socket pin screw	6	520-1122
M M6 x 12 mm socket pin screw	4	520-1050
N M6 x 25 mm socket pin screw	4	520-1211
O M5 x 20 mm socket pin screw	2	520-1065
P 4 mm allen wrench	1	560-9646

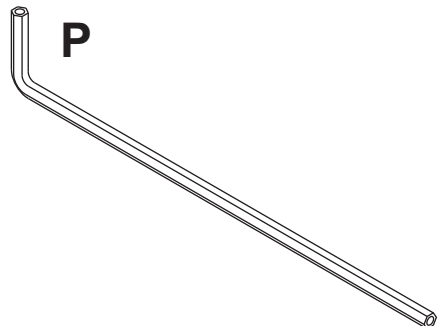
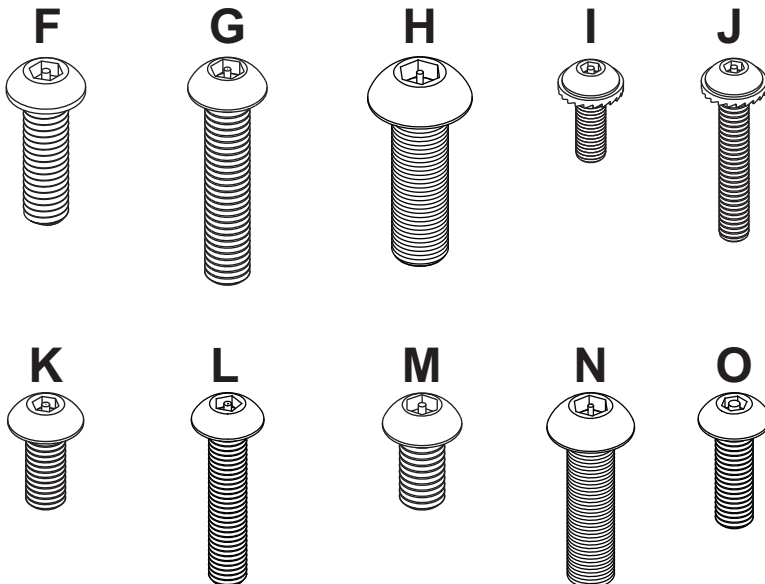
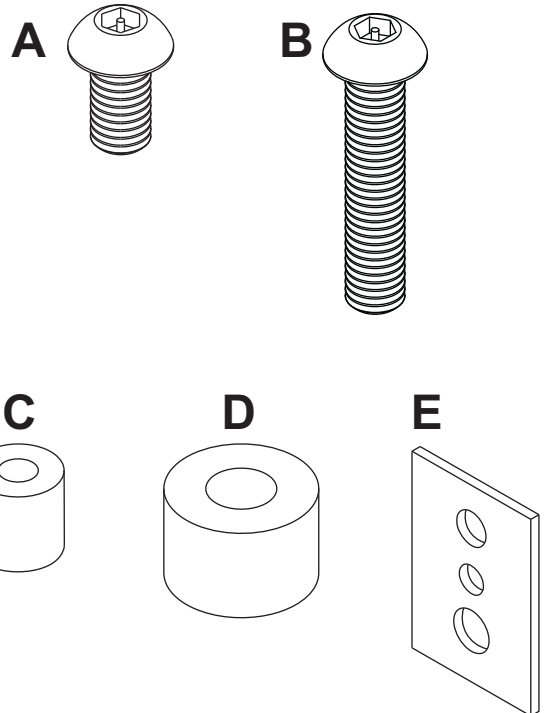

Installing Security Screws for PF and PT wall mount models

Replacing Safety/Security Screw

1

NOTE: If installing security screws for SA wall mount models, skip to page 6.

Replace safety/security screws with M5 x 25 mm screw (L). Hand thread screw into bottom of flat or tilt adapter bracket as shown in figure 1.1 and 1.2.

NOTE: Be sure tip of screw is flush with top of adapter bracket hole.

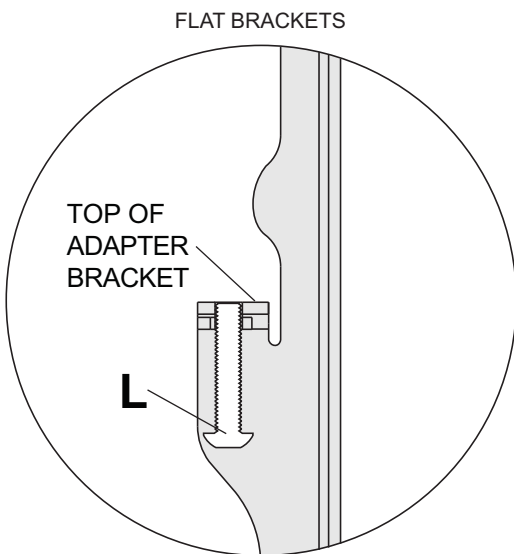

fig 1.1

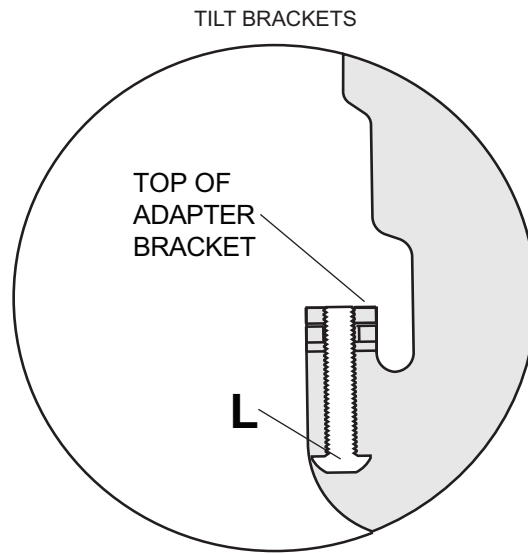

fig 1.2

⚠ WARNING

- Tighten screws so adapter brackets are firmly attached. Do not tighten with excessive force. Overtightening can cause stress damage to screws, greatly reducing their holding power and possibly causing screw heads to become detached. Tighten to 40 in. • lb (4.5 N.M.) maximum torque.
- If screws don't get three complete turns in the screen inserts or if screws bottom out and bracket is still not tightly secured, damage may occur to screen or product may fail.

2 To prevent scratching the screen, set a cloth on a flat, level surface that will support the weight of the screen. Place screen face side down. If screen has knobs on the back, remove them to allow the adapter brackets to be attached. Place flat or tilt brackets (not included) on back of screen, align to holes, and center on back of screen as shown below. Attach the adapter brackets to the back of the screen using the appropriate combination of security screws, multi-washers, and spacers as shown in steps 2-1 and 2-2 on page 4.

NOTE: Top and bottom holes on screen must always be used.

Verify that all holes are properly aligned, and then tighten screws using a phillips screwdriver.

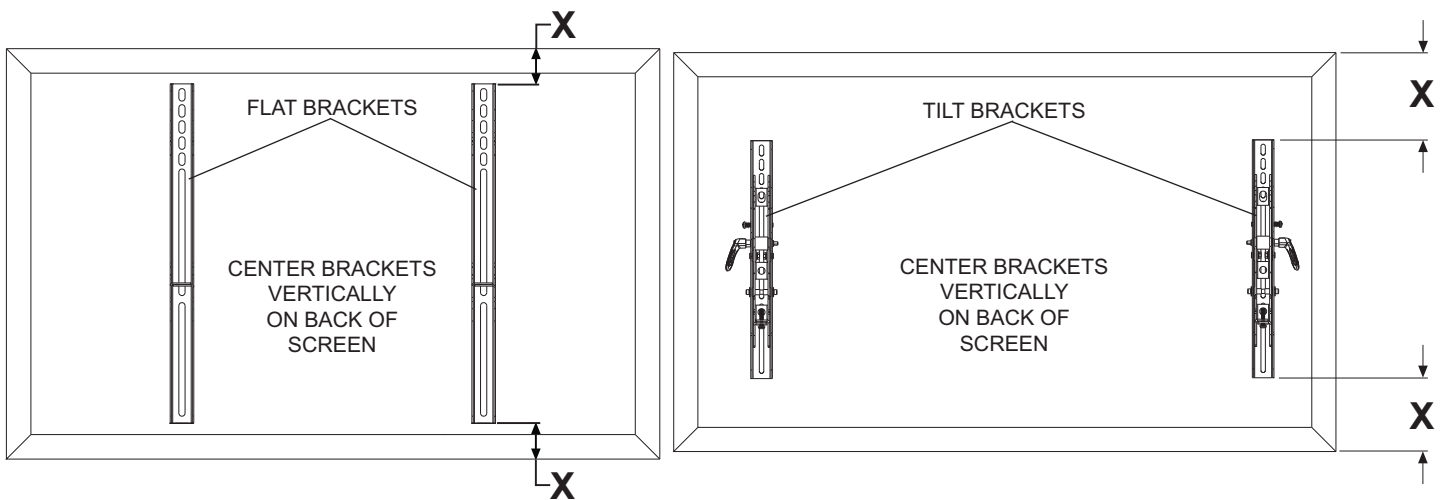

NOTE: "X" dimensions should be equal.

MULTI-WASHER (E)

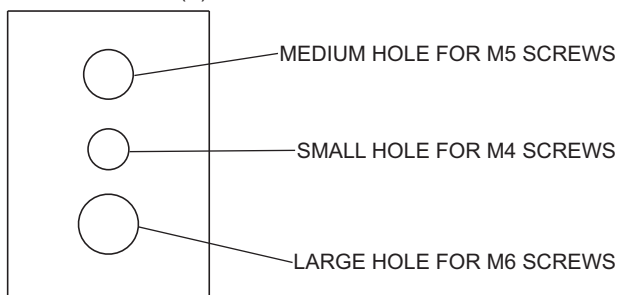

Notes:

- The number of fasteners used will vary, depending upon the type of screen.
- Multi-washers (E) and spacers (C and D) may not be used, depending upon the type of screen.
- Use the corresponding hole in the multi-washer that matches your screw size.

NOTE: For **flat back screens** proceed to step 2-1. For **bump-out or recessed back screen** skip to step 2-2.

For Flat Back Screen

2-1 Begin with the shortest length screw, hand thread through multi-washer and flat or tilt adapter bracket (not included) into screen as shown below. Screw must make at least three full turns into the mounting hole and fit snug into place. Do not over tighten. If screw cannot make three full turns into the screen, select a longer length screw from the security fastener pack. Repeat for remaining mounting holes, level brackets and tighten screws.

NOTE: Spacers may not be used, depending upon the type of screen.

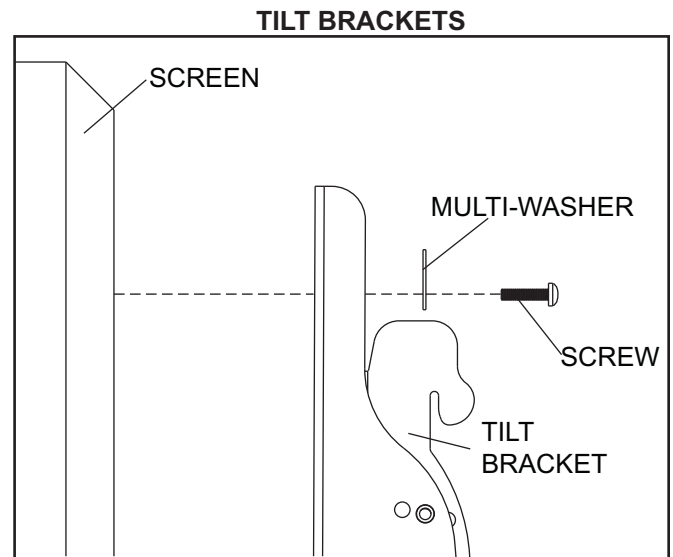
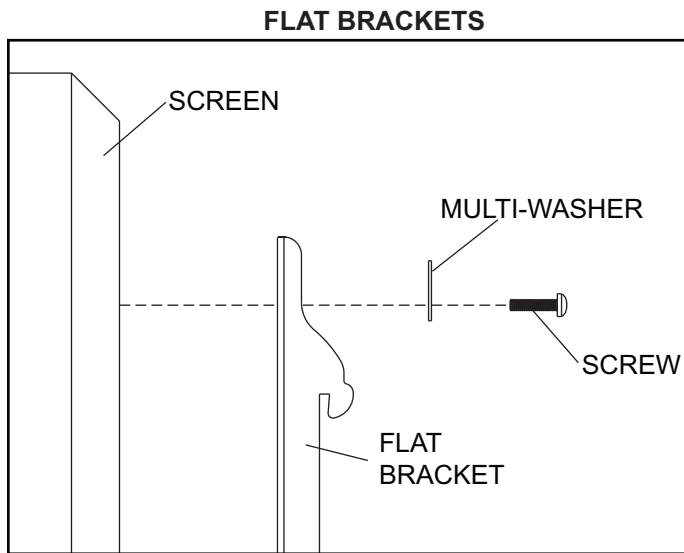

If you have any questions, please call Peerless customer care at 1-800-865-2112.

For Bump-out or Recessed Back Screen

2-2 Begin with longer length screw, hand thread through multi-washer, flat or tilt adapter bracket (not included) and spacer in that order into screen as shown below. Screw must make at least three full turns into the mounting hole and fit snug into place. Do not over tighten. If screw cannot make three full turns into the screen, select a longer length screw from the security fastener pack. Repeat for remaining mounting holes, level brackets and tighten screws.

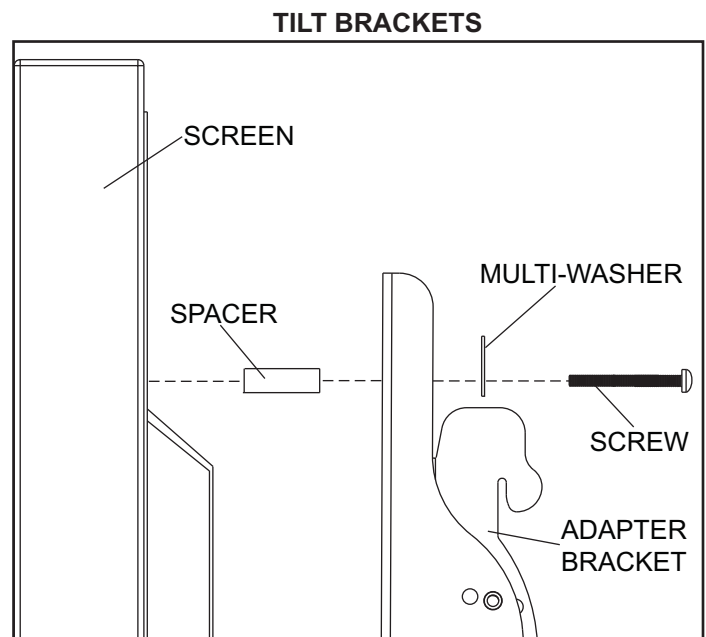
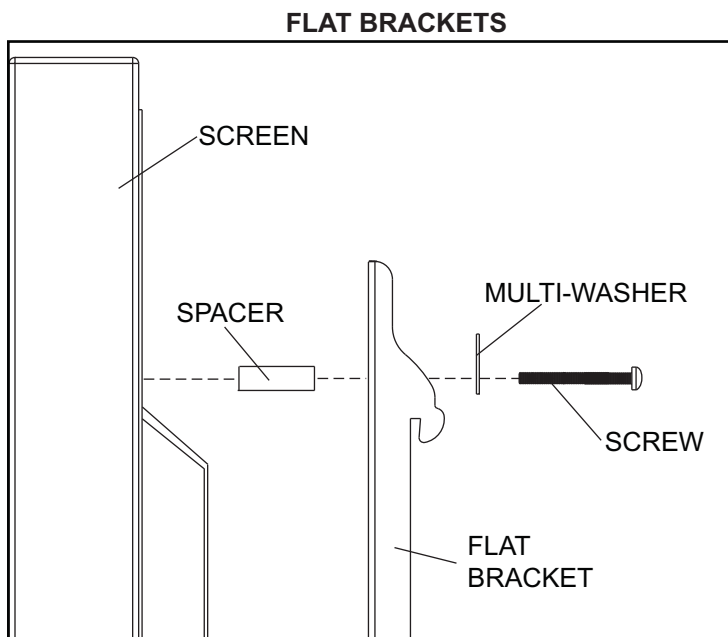

If you have any questions, please call Peerless customer care at 1-800-865-2112.

Installing Adapter Brackets

⚠ WARNING

- Always use an assistant or mechanical lifting equipment to safely lift and position the flat panel screen.
- Do not tighten screws with excessive force. Overtightening can cause damage to mount. Tighten screws to 40 in. • lb (4.5 N.M.) maximum torque.
- Be careful not to pinch fingers when pushing screen from the bottom.

3 Hook flat brackets onto wall plate (not included). Then slowly swing screen in as shown in figure 3.1. Using 4 mm security allen wrench (**P**) turn clockwise until screw fits firmly against wall plate to prevent screen from being removed. Screen can be adjusted horizontally by loosening M5 x 25 mm screw (**L**) on flat brackets.

NOTE: To lock the screen down, tighten safety/security screws (**L**) to wall plate as shown.

To remove screen from mount, loosen safety/security screws, swing screen away from mount, and lift screen off of mount.

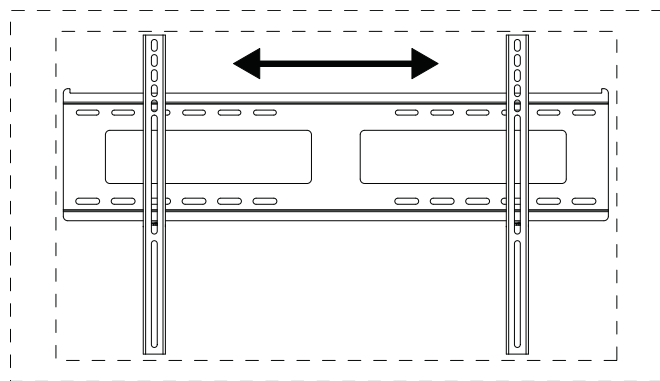

fig 3.2

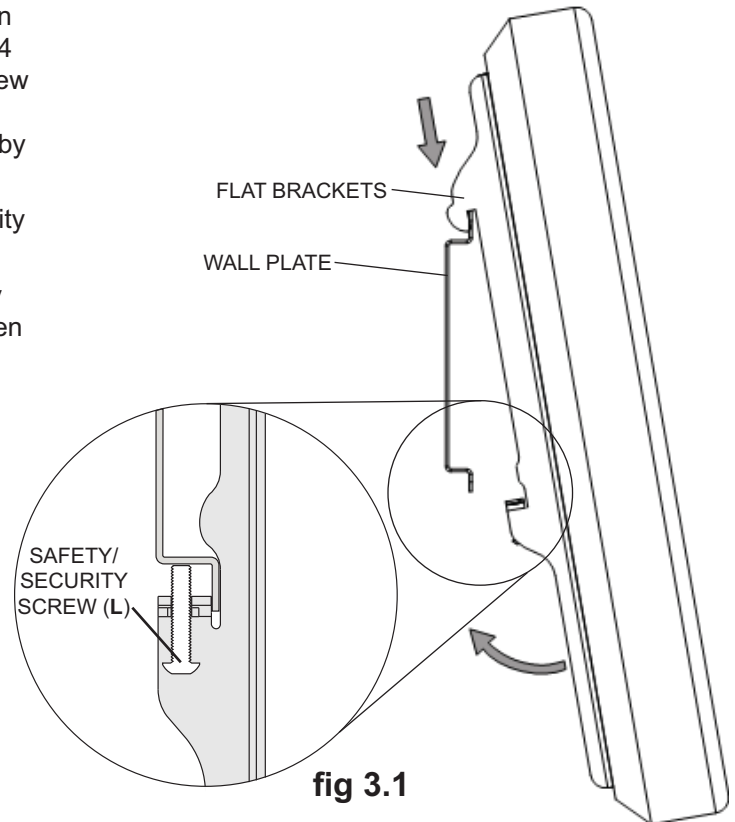

fig 3.1

3-1 Adjust tension in tilt brackets by rotating ratchet handle. **NOTE:** If obstruction prevents ratchet handle from rotating, pull handle out while turning will allow handle to reposition without tightening. Release and turn handle to tighten or loosen.

Ratchet handle must be in the up or down position, or interference will occur while hooking tilt brackets to wall plate. Slowly hook tilt brackets onto wall plate and swing screen down. Using 4 mm security allen wrench (**P**) turn clockwise until screw fits firmly against wall plate to prevent screen from being removed as shown in figure 3.3.

To remove screen from mount, loosen safety/security screws, swing screen away from mount, and lift screen off of mount.

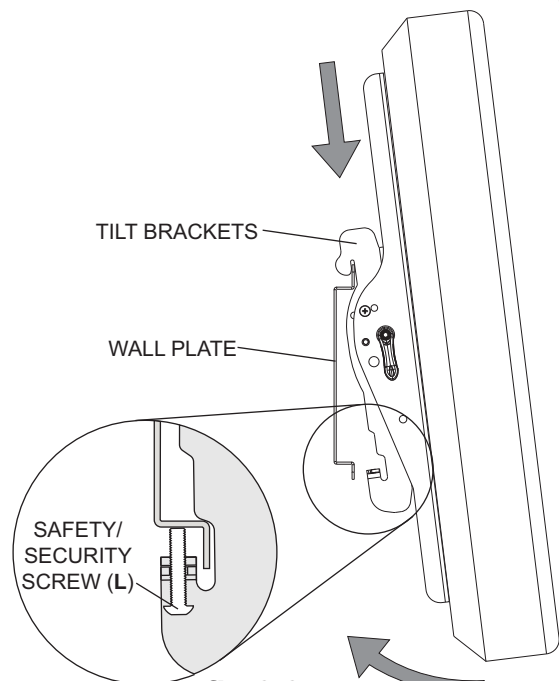

fig 3.3

Installing Security Screws for SA wall mount models

⚠ WARNING

- Tighten screws so screen brackets are firmly attached to screen. Do not tighten with excessive force. Overtightening can cause stress damage to screws, greatly reducing their holding power and possibly causing screw heads to become detached. Tighten to 40 in. • lb (4.5 N.M.) maximum torque.
- If screws don't get three complete turns in the screen inserts or if screws bottom out and bracket is still not tightly secured, damage may occur to screen or product may fail.

- 1** **NOTE:** Refer to main instructions for adjustments of universal adapter bracket extension brackets.
NOTE: If your screen has a VESA hole pattern skip to page 8.

To prevent scratching the screen, set a cloth on a flat, level surface that will support the weight of the screen. Place screen face side down. Refer to screen manufacturer's instructions for removal of knobs, base, cover, or screw(s) on the back of the screen to prepare for mounting screen brackets to screen. Adjust screen brackets to align with screen mounting holes as shown below. Select the small, medium, large or extra large screws from the security fastener pack then attach screen brackets to screen following steps 1-1 and 1-2 on page 7.

NOTE: Top and bottom mounting holes must be used for attaching screen brackets. Middle holes should also be used where the fasteners and screens allow.

Verify that all holes are properly aligned, and then tighten screws using a phillips screw driver.

If installing security screws for PF or PT wall mount models, go to page 2.

CENTER SCREEN BRACKETS VERTICALLY ON BACK OF SCREEN

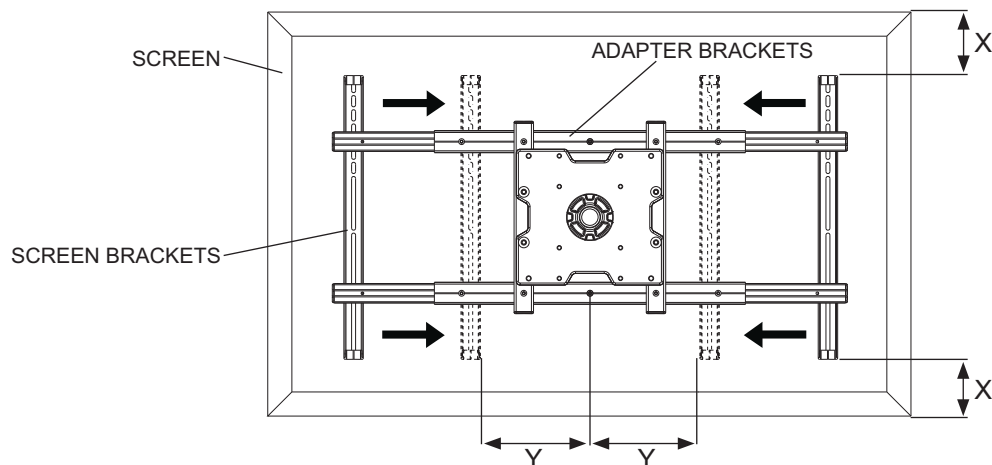

NOTE: "X" dimensions should be equal.
"Y" dimensions should be equal.

MULTI-WASHER (E)

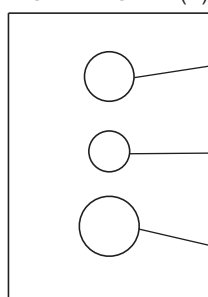

MEDIUM HOLE FOR M5 SCREWS

SMALL HOLE FOR M4 SCREWS

LARGE HOLE FOR M6 SCREWS

Notes:

- The number of fasteners used will vary, depending upon the type of screen.
- Multi-washers (E) and spacers (C and D) may not be used, depending upon the type of screen.
- Use the corresponding hole in the multi-washer that matches your screw size.

NOTE: For flat back screens proceed to step 1-1. For bump-out or recessed back screen skip to step 1-2.

For Flat Back Screen

1-1 Begin with the shortest length screw, hand thread screw through multi-washer and screen brackets (not included) into screen as shown below. Screw must make at least three full turns into the mounting hole and fit snug into place. Do not over tighten. If screw cannot make three full turns into the screen, select a longer length screw from the fastener pack. Repeat for remaining mounting holes, level screen brackets and tighten screws.

NOTE: Spacers may not be used, depending upon the type of screen.

If you have any questions, please call Peerless customer care at **1-800-865-2112**.

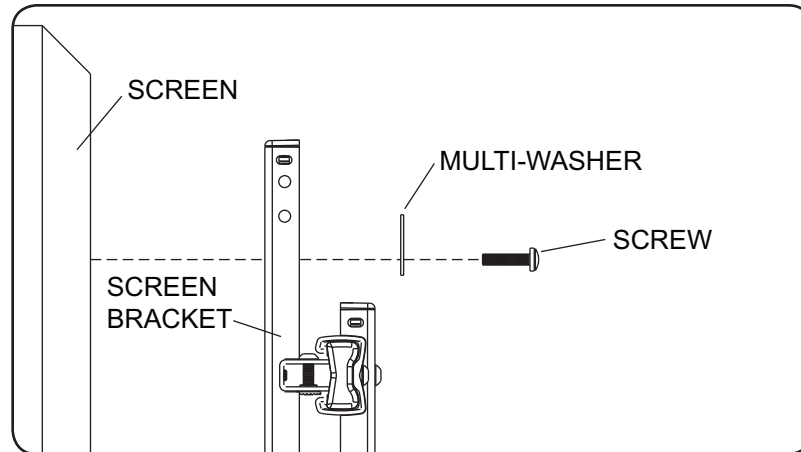

For Bump-out or Recessed Back Screen

1-2 Begin with longer length screw, hand thread screw through multi-washer, screen brackets (not included) and spacer in that order into screen as shown below. Screw must make at least three full turns into the mounting hole and fit snug into place. Do not over tighten. If screw cannot make three full turns into the screen, select a longer length screw from the fastener pack. Repeat for remaining mounting holes, level screen brackets and tighten screws.

If you have any questions, please call Peerless customer care at **1-800-865-2112**.

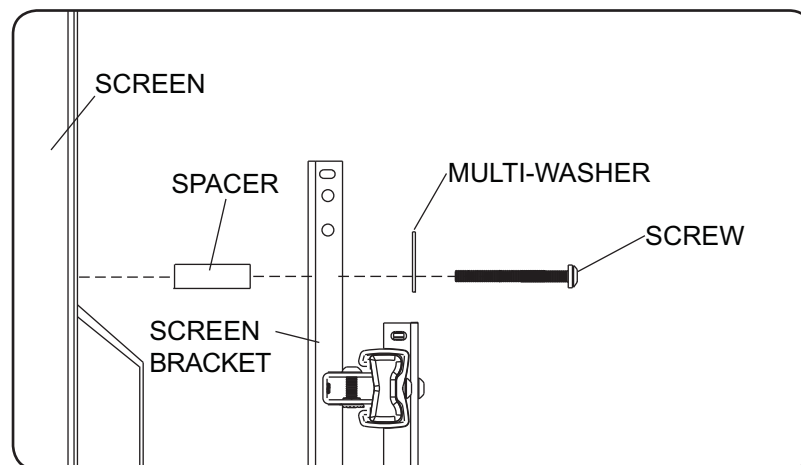

Attaching Adapter Plate to Screen with VESA® Mounting Pattern

- 2** Choose hole pattern as shown in detail 1 for VESA mounting pattern. Begin with the shortest length screw, hand thread through adapter plate into screen as shown in detail 2. Screw must make at least three full turns into the mounting hole and fit snug into place. Do not over tighten. If screw cannot make three full turns into the screen, select a longer length screw from the fastener pack. Repeat for remaining mounting holes. Securely tighten screws.

NOTE: Spacers may not be used, depending upon the type of screen.

If you have any questions, please call Peerless customer care at **1-800-865-2112**.

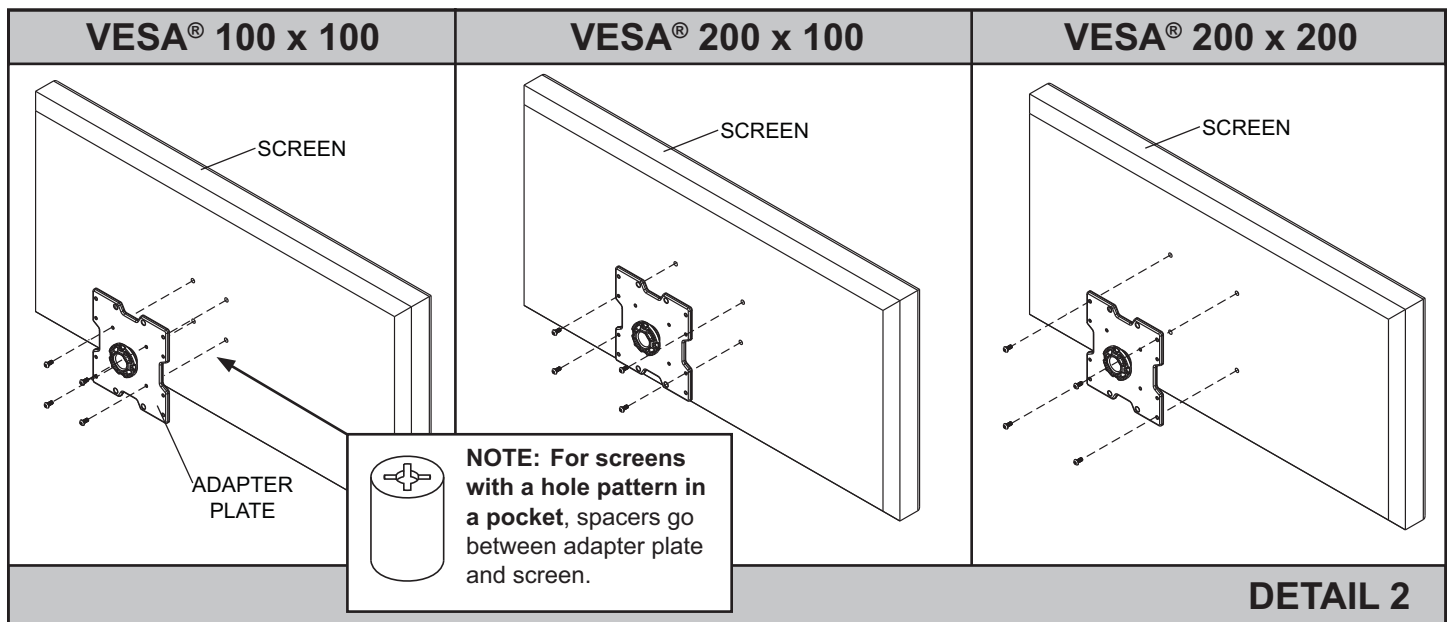
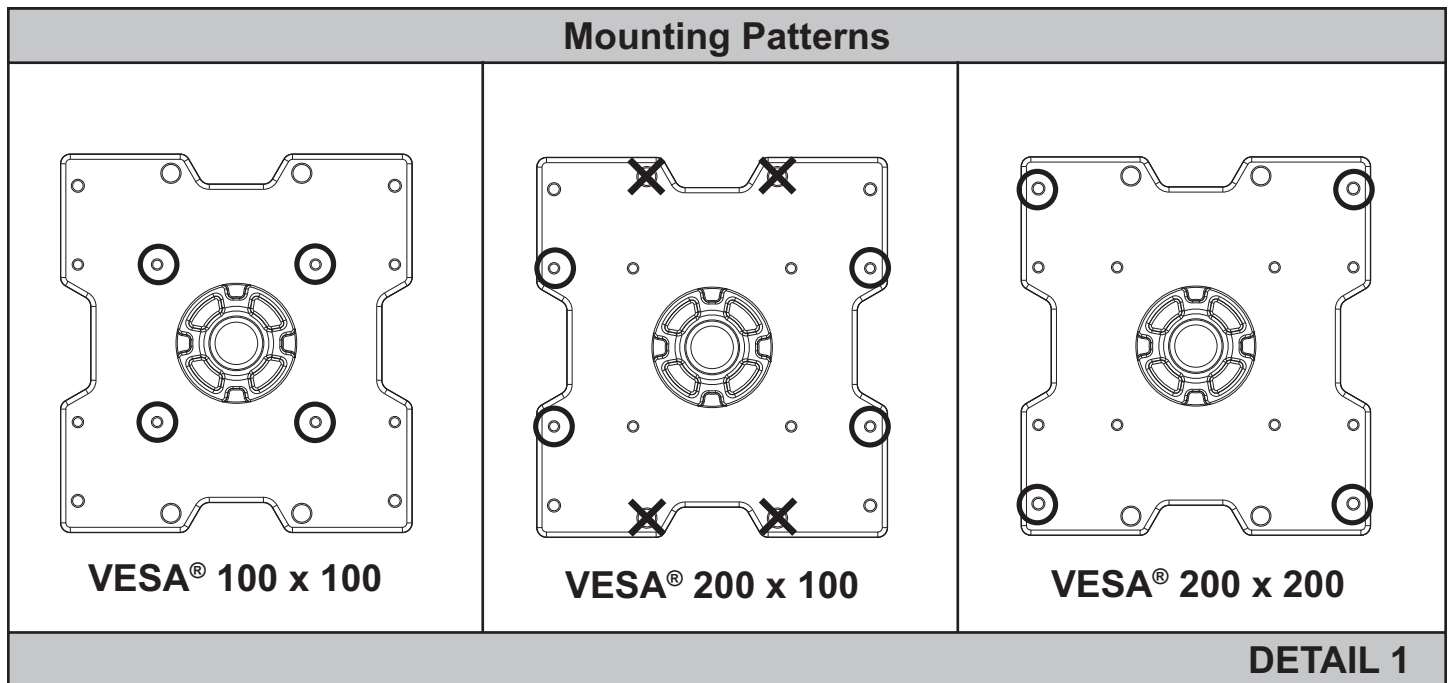

⚠ WARNING

- Do not lift more weight than you can handle. Use additional man power or mechanical lifting equipment to safely handle placement of the screen.
- Failure to lock brake pad with two M5 x 20 mm screws (O) and lock tilt bracket with M5 x 25 mm screw (L) can cause screen to come off mount if hit accidentally.

Installing and Removing Flat Panel Screen

- 3** To attach screen to arm (not included), insert the puck of adapter plate into the tilt bracket slot as shown in figure 3.1. Attach brake pad assembly as shown in Detail 3 so that the brake pad is snug against the adapter plate. Adjust roll position of adapter plate to level screen then lock puck in place by tightening M5 x 25 mm screw (L) on the underside of tilt bracket using 4 mm allen wrench (P). Tighten all (M5 x 20 mm, M5 x 25 mm) screws.
- NOTE:** To remove screen from arm, remove two M5 x 20 mm screws (O) and brake pad. Lift screen out of tilt bracket.

CAUTION

- Do not tighten screws with excessive force. Overtightening can cause damage to mount. Tighten M5 x 20 mm screws (O) to 20 in. • lb (2.26 N.M.) maximum torque.

