

SA752PU SA752P

SmartMount® Articulating Wall Arm For 32" to 52" Flat Panel Displays

From any angle, this wall arm mount reflects remarkable form and function. Extending the flat panel display up to 27.43" (697mm) from the wall and allowing for a full 180° of side-to-side motion for perfect view positioning of displays up to 52". Fine-tuning of the installation is simple with its side-to-side display leveling and 1" (25.4mm) of vertical adjustment features that help achieve perfection. This articulating arm also provides display centering on the wall plate and integrates a desirable cable management system, centering the flat panel display on the wall when retracted and organizing and protecting the cables. Designed and built in the USA, this mount maintains the same brilliant look as the entire SmartMount® 700 Series line of Articulating and Pivot Wall Arm Mounts.



Display size: 32"-52"



Max load: 90lb (41kg)



FEATURES

- Universal model SA752PU provides compatibility for 32" to 52" flat panel displays with mounting patterns up to 689 x 439mm (27.12" x 17.29")
- Dedicated model SA752P requires display adapter to be purchased separately
- Display can be held as close to the wall as 4.43" (112mm) or be extended as far as 27.43" (697mm)
- Integrated cable management contains, protects and conceals cables for a clean clutter-free look
- One-touch tilt allows for +15°/-5° without the use of tools for easy viewing angle adjustment
- Multi-link construction allows for a full 180° range of motion
- Display can be pivoted a full 90°
- ±5° of roll allows for post installation leveling
- Display can be rotated from portrait to landscape without removing the display for easy orientation changes
- 1" (25.4mm) vertical adjustment for display position fine tuning

* OSHPD Approval Pending

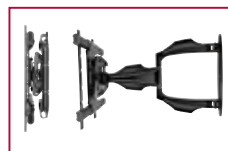
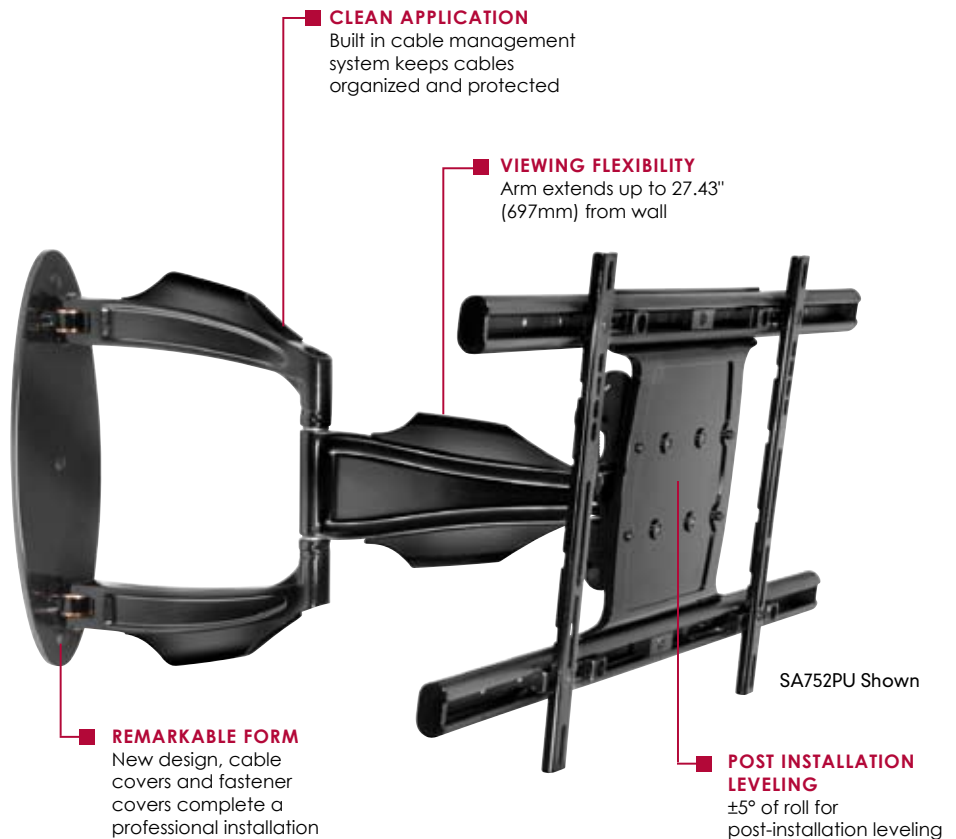

Arm retracts to just 4.43" (112mm) and extends up to 27.43" (697mm) from wall

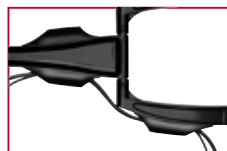

1" (25.4mm) clearance per channel for clean and simple cable management



1" (25.4mm) of vertical adjustment for post-installation fine tuning



SA752P dedicated model requires additional adapter plate for mounting display



Model Numbers

WARRANTY: Limited 5-year

SA752PU	Universal Articulating Wall Arm for 32" to 52" Flat Panel Displays
SA752P	Dedicated Articulating Wall Arm for 32" to 52" Flat Panel Displays

Product Specifications

	DIMENSIONS (W x H x D)	PRODUCT WEIGHT	LOAD CAPACITY	FINISH	AVAILABLE COLORS
SA752PU	28.68" x 18" x 4.43"-27.43" (728 x 457 x 112-697mm)	33lb (15kg)	90lb (41kg)	Scratch resistant fused epoxy	Gloss black
SA752P	15.2" x 17" x 2.73"-25.73" (386 x 431 x 69-654mm)	18lb (8kg)			

Package Specifications

	PACKAGE SIZE (W x H x D)	PACKAGE SHIP WEIGHT	PACKAGE UPC CODE	PACKAGE CONTENTS	UNITS IN PACKAGE
SA752PU	35.75" x 21.25" x 5.625" (908 x 540 x 143mm)	38lb (17.3kg)	SA752PU: 735029266563	Mount, wall and display attachment hardware, installation instructions	1
SA752P		22lb (10kg)	SA752P: 735029270232		

Accessories

ACC925:	Security Fastener Pack
WSP756:	Metal Stud Wall Plate Accessory

All dimensions = inch (mm)

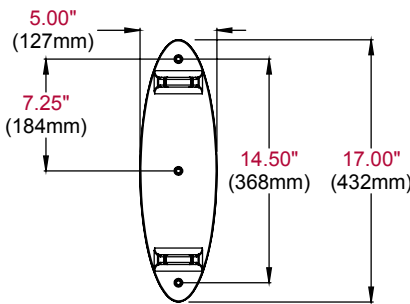

WALL PLATE

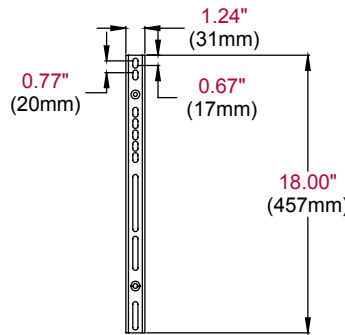

VERTICAL ADAPTER

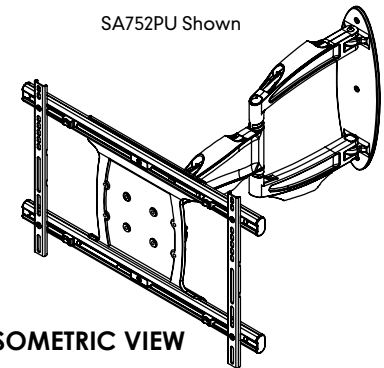

ISOMETRIC VIEW

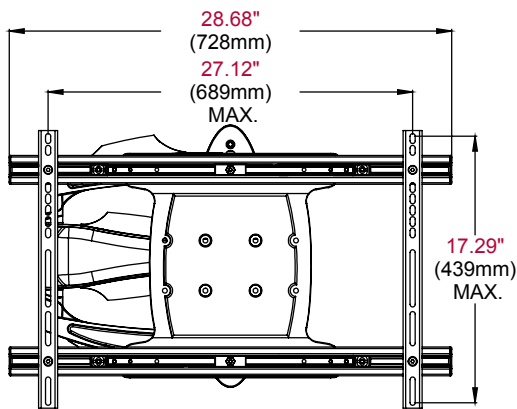

FRONT VIEW

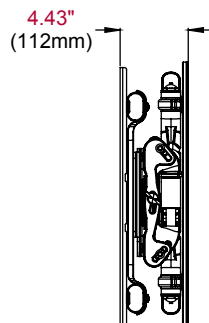

**SIDE VIEW
RETRACTED**

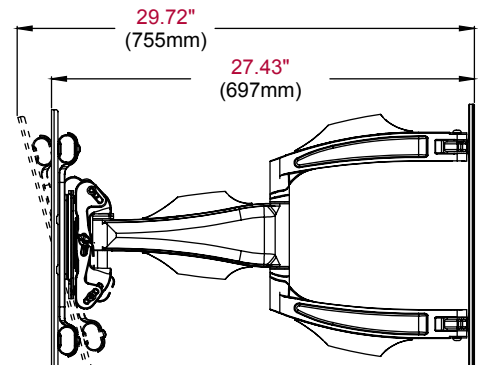

**SIDE VIEW
EXTENDED**

ARCHITECTS SPECIFICATIONS

The SmartMount Articulating Wall Mount shall be a Peerless-AV model SA752PU and shall be located where indicated on the plans. It shall feature scratch resistant black or silver fused epoxy finish. Assembly and installation shall be done according to instructions provided by the manufacturer.

Peerless Industries, Inc. ■ 2300 White Oak Circle ■ Aurora, IL 60502 ■ (800) 865-2112 ■ (630) 375-5100 ■ Fax: (800) 359-6500 ■ www.peerless-av.com

Visit www.peerless-av.com to see the complete line of AV solutions from Peerless-AV, including flat panel mounts, projector mounts, carts/stands, furniture, cables, screen cleaners and a full assortment of accessories.