

# TECHNICAL DATA SHEET - Jumbo™ 44" Wide Body Cart

# peerless®

MODEL: JCT WB44 & JCT WB44E

The wide base on these carts provides extra stability, making them ideal for use in schools, libraries, and media centers. Three stationary shelves provide ample space for TVs (up to 32"), extra audiovisual equipment, and supplies. Available with a three-outlet electrical strip with cord wrap bracket for powering equipment.

### Features:

- Color: Black
- 44" high wide - body design, for use with projector or monitor up to 32"
- 4" silent roll bearings swivel casters, 2 locking
- Three shelves- Dimensions  
 Top shelf - 32" L x 21.8" W  
 Middle shelf - 32" L x 27" W  
 Bottom shelf - 32" L x 27" W
- Solid Steel construction
- "E" model includes three outlet electrical strip with 15' power cord

### Dimensions:

#### Weight:

JCT WB44E - 55.6 lb (25.2 kg)  
 JCT WB44 - 53.3 lb (24.2 kg)

#### Shipping weight:

JCT WB44E - 64.3 lb (29.2 kg)  
 JCT WB44 - 62 lb (28.1 kg)

#### Shipping Carton dimensions:

L= 41 in (1041 mm)  
 W= 35.5 in (902mm)  
 H= 5 in (127 mm)

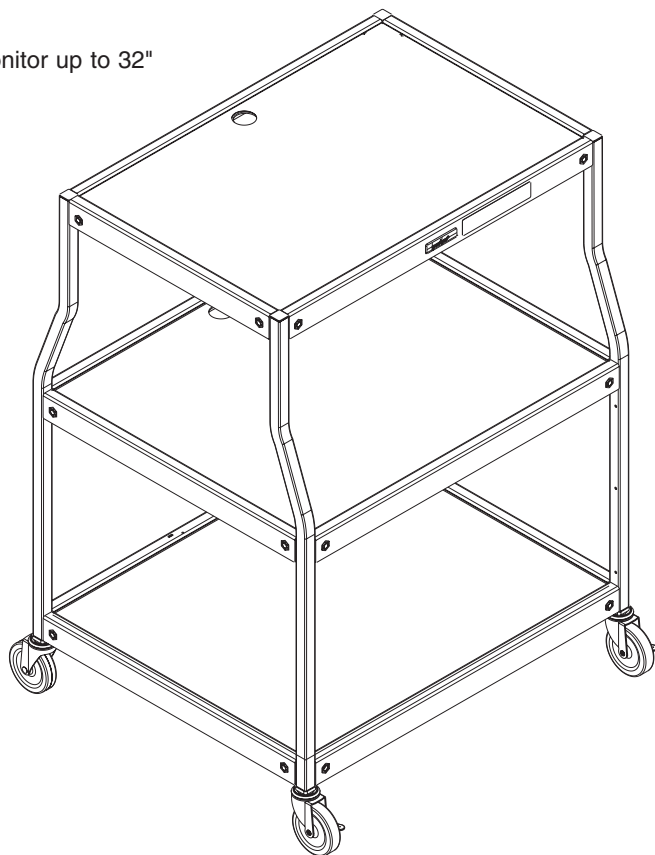

## ARCHITECTS SPECIFICATIONS

The Jumbo™ Wide body cart shall be a Peerless model **JCT WB44 & JCT WB44E** and shall be located where indicated on the plans. It shall be constructed of solid steel and finished in black paint. Assembly and installation shall be done according to instructions provided by the manufacturer.

Peerless Industries, Inc.  
 3215 W. North Ave. Melrose Park, IL 60160  
 708-865-8870 800-865-2112 Fax 708-865-2941  
[www.peerlessmounts.com](http://www.peerlessmounts.com)

ISSUED: 06-23-03 SHEET NO: 009-9522-6 07-09-07

©2007, Peerless Industries, Inc. All rights reserved.  
 All other brand and product names are trademarks or registered trademarks of their respective owners.

TECHNICAL DATA SHEET

MODEL: JCT WB44 & JCT WB44E

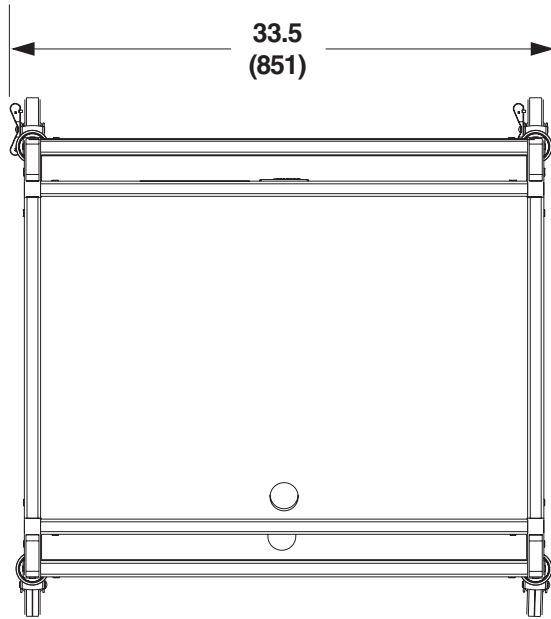

ALL DIMENSION = INCH  
(MM)

