

# TECHNICAL DATA SHEET - Overhead Projector Cart



MODELS: JCT-MOC29E, JCT-MOC39E

This Overhead Projector Cart with two flip down leaves is perfect for applications that require mobility and compatibility while providing a space saving solution for projector use and storage. This easy to assemble cart features silent roll casters, an adjustable height projector platform that is compatible with most types of overhead projectors and a three outlet electrical strip with cord management wrap. Ideal for use in schools, libraries, media centers and hotels.

**Features:**

- Color: Black
- Easy to assemble
- Adjustable height projector platform
- Two drop down leaves provide extra usable space
- Included electrical strip with cord management wrap
- Four 4" silent-roll full swivel ball bearing casters, two with locks
- Shelves are constructed of 20 gauge steel
- Two fold down side shelves
- Bottom shelf for extra storage (JCT-MOC39E only)
- Lifetime Warranty

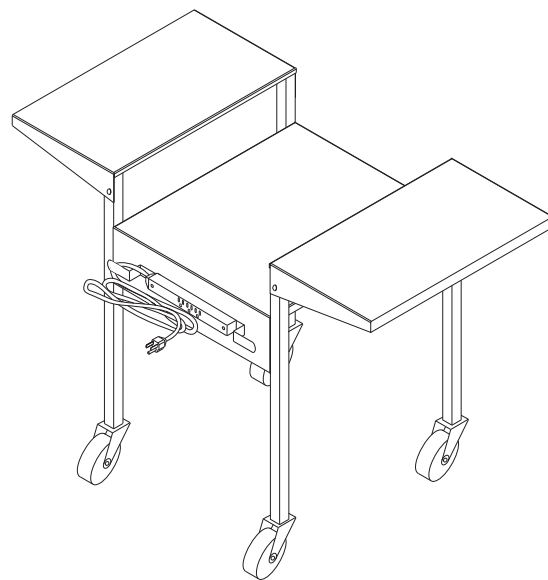

**JCT-MOC29E**

**Dimensions:**

**Weight:**

30 lb (13.6 kg)

**Shipping weight:**

36 lb (16.3 kg)

**Maximum Load Capacity:**

125 lb (56.7 kg)

**Shipping Carton dimensions:**

L= 25.75 in (654 mm)

W= 21.75 in (552 mm)

H= 8.5 in (216 mm)

**JCT-MOC39E**

**Dimensions:**

**Weight:**

40 lb (18.1 kg)

**Shipping weight:**

46 lb (20.9 kg)

**Maximum Load Capacity:**

125 lb (56.7 kg)

**Shipping Carton dimensions:**

L= 25.75 in (654 mm)

W= 21.75 in (552 mm)

H= 8.5 in (216 mm)

## ARCHITECTS SPECIFICATIONS

The Overhead Projector Cart shall be a Peerless model **JCT-MOC29E** or **JCTMOC39E** and shall be located where indicated on the plans. It shall be constructed of 20 gauge steel. Assembly and installation shall be done according to instructions provided by the manufacturer.

**Peerless Industries, Inc.**

3215 W. North Ave. Melrose Park, IL 60160

708-865-8870 800-865-2112 Fax 708-865-2941

[www.peerlessmounts.com](http://www.peerlessmounts.com)

ISSUED: 06-24-05 SHEET NO: 009-9527-2 09-03-08

©2008 Peerless Industries, Inc. All rights reserved.  
Peerless is a registered trademark of Peerless Industries, Inc.

TECHNICAL DATA SHEET

MODELS: JCT-MOC29E, JCT-MOC39CE

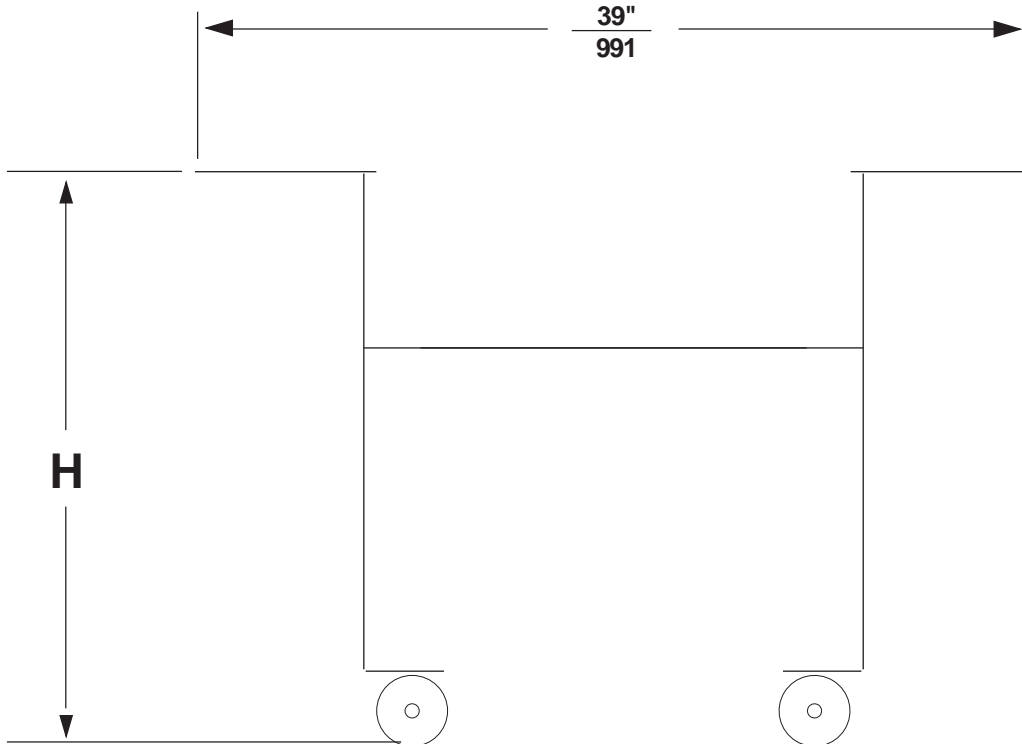
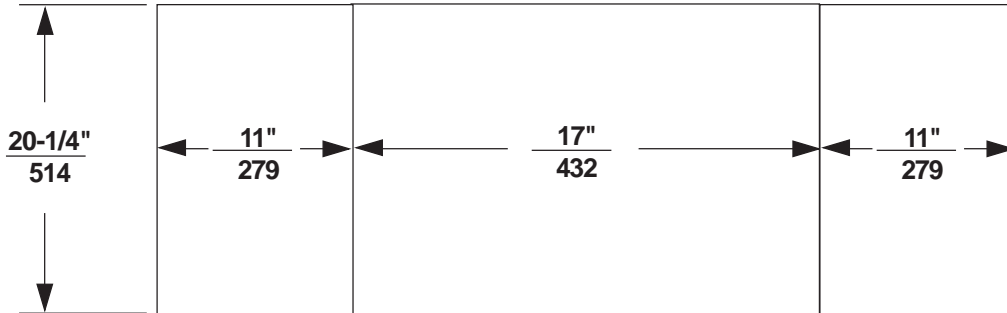

	JCT-MOC29E	JCT-MOC39CE
<b>H</b>	$\frac{29"}{737}$	$\frac{39"}{991}$