

TECHNICAL DATA SHEET -

MODEL: PS200

PARAMOUNT TM by Peerless

**Paramount™ A/V
Component Shelf**

A versatile solution that not only looks great, but let's you easily incorporate A/V components into virtually any environment. This flexible and space-saving shelf gets A/V components organized and out of the way. It offers a low-profile solution that mounts to two studs allowing you to center components under the screen, completing the picture-perfect installation.

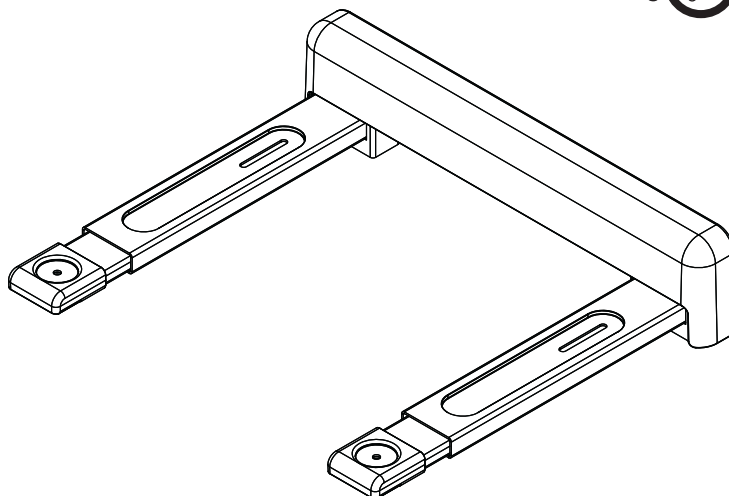

Features:

- Double-stud installation allows A/V equipment to be centered directly underneath flat panel TV
- Compact design is ideal for smaller spaces or A/V closets
- 100 lb load capacity allows stacking of all components
- Decorative snap-on covers conceal all mounting hardware
- Adjustable width up to 18" and depth range of 15" to 23" accommodate even largest receivers, multi-disk DVD players
- Leveling feature ensures equipment is always level
- Embossed arms with screw holes secure components to shelf

Other Accessories:

- Metal stud accessory kit ACC 215 (sold separately)
- Safety Belt (ACC 322) (sold separately)

Dimensions:

Weight:

8.8 lb (4 kg)

Shipping weight:

10.7 lb (4.85 kg)

Maximum Load Capacity:

100 lb (45.4 kg)

Shipping Carton dimensions:

L = 22.25 in (565 mm)

W = 9.5 in (241 mm)

H = 4.25 in (108 mm)

ARCHITECTS SPECIFICATIONS

The **Paramount™ A/V Component Shelf** shall be a Peerless model _____ and shall be located where indicated on the plans. It shall be constructed of heavy gauge steel. The finish shall be scratch resistant gloss black fused epoxy. Assembly and installation shall be done according to instructions provided by the manufacturer.

Peerless Industries, Inc.

3215 W. North Ave. Melrose Park, IL 60160
708-865-8870 800-865-2112 Fax 708-865-2941

www.peerlessmounts.com

ISSUED: 07-13-07 SHEET NO: 083-9503-2 04-14-08

©2008, Peerless Industries, Inc. All rights reserved.
All other brand and product names are trademarks or registered trademarks of their respective owners.

TECHNICAL DATA SHEET -

MODEL: PS200

All dimensions = inch (mm)

SIDE VIEW

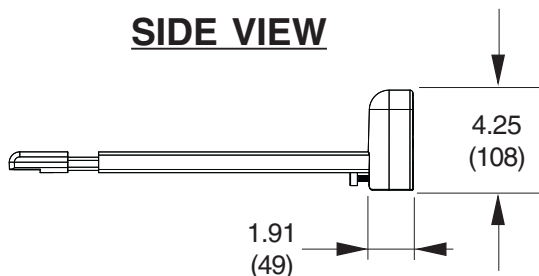

FRONT VIEW

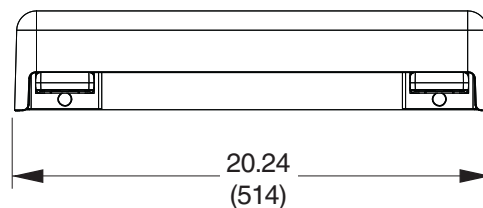

TOP VIEW

**MAXIMUM EXTENDED WIDTH
MINIMUM RETRACTED LENGTH**

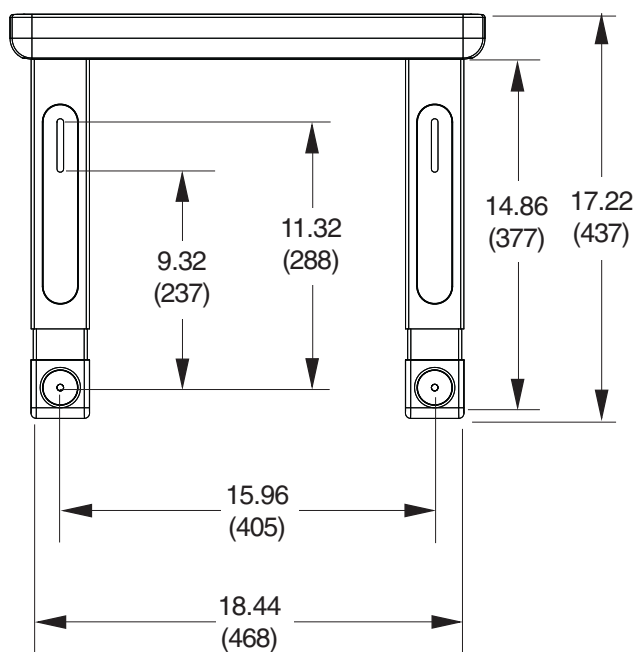

TOP VIEW

**MINIMUM RETRACTED WIDTH
MAXIMUM EXTENDED LENGTH**

