

TECHNICAL DATA SHEET - Straight Column Flat Panel Ceiling Mount for 32" to 60" LCD And Flat Panel Screens

peerless®

MODEL: PLCM UNL

This product is intended for use with UL Listed products and must be installed by a qualified professional installer.

The Straight Column Ceiling Mount offers a straight column from the ceiling attachment point to the flat panel screen. The straight column ceiling mount is ideal for sports facilities, airports, lobbies or retail environments.

Features:

- PLCM-UNL models include a PLP-UNL adapter plate (landscape only)
- 0° to 20° adjustable tilt and 360° swivel
- Screen mounts horizontally
- Uses standard 1 1/2" – 11.5 NPT schedule 40 pipe
- Additional length can be added for lowering
- Theft-resistant security fasteners secure the screen to the mount
- Sold without ceiling plate
- Complete detailed installation instructions for wood and concrete structures

Accessories:

- Ceiling Plate required (sold separately). Various options available. Other ceiling accessories can be ordered separately to allow mounting to I-beams, cathedral ceilings, trusses, etc.

Dimensions:

Weight:

23.1 lb (10.5 kg)

Shipping weight:

30.3 lb (13.7 kg)

Maximum Load Capacity:

200 lb (90.7 kg)

Shipping Carton dimensions:

BOX1

L = 31.625 in (803 mm)

W = 8.375 in (213 mm)

H = 4.375 in (111 mm)

Weight = 14.3 lb (6.49 kg)

BOX2

L = 36.75 in (933 mm)

W = 11.5 in (292 mm)

H = 3.75 in (95 mm)

Weight = 16 lb (7.26 kg)

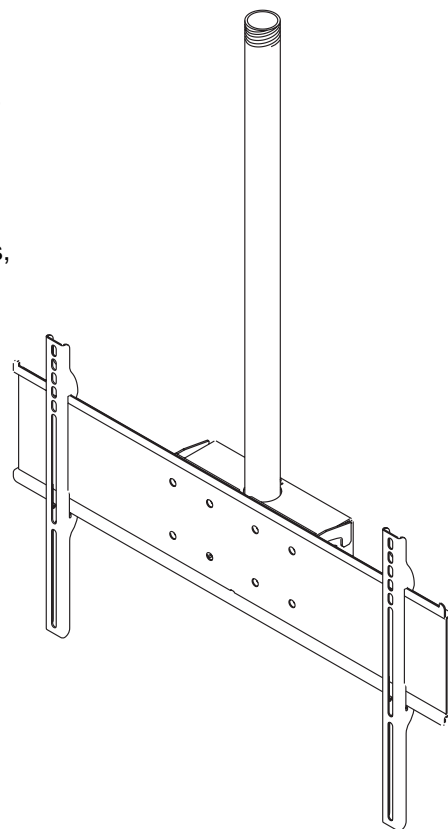

ARCHITECTS SPECIFICATIONS

The Straight Column Flat Panel Ceiling Mount shall be a Peerless model **PLCM UNL** and shall be mounted where indicated on the plans. It shall be constructed of heavy gauge cold rolled steel, steel tubing and finished with scratch resistant Black Fused Epoxy. It shall feature 360° swivel and 0° to 20° range of tilt. Assembly and installation shall be done according to instructions provided by the manufacturer.

Peerless Industries, Inc.

3215 W. North Ave. Melrose Park, IL 60160
708-865-8870 800-865-2112 Fax 708-865-2941

www.peerlessmounts.com

ISSUED: 07-31-06 SHEET NO: 200-9831-2 09-05-07

©2007, Peerless Industries, Inc. All rights reserved.
All other brand and product names are trademarks or registered trademarks of their respective owners.

TECHNICAL DATA SHEET

MODEL: PLCM UNL

ALL DIMENSION = INCH (UNLESS OTHERWISE SPECIFIED)
(MM)

A = 34.26" (870 mm) when used with 33" (838 mm) extension column Landscape: $X = A - (1/2 \text{ (height of screen)}) - 2.68" (68 \text{ mm})$

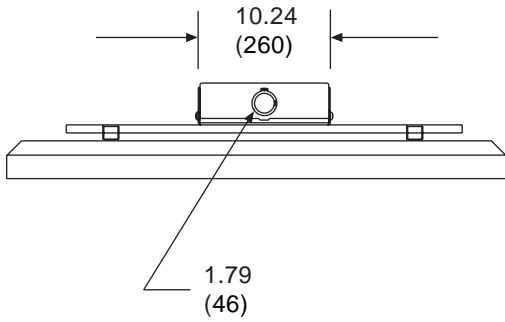

TOP VIEW

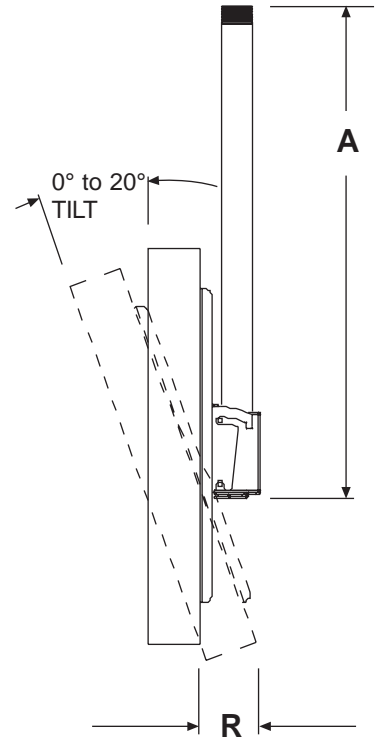

SIDE VIEW

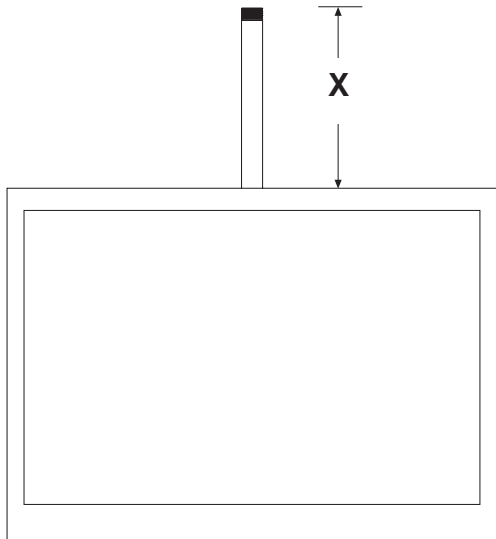

Landscape: $X = A - (1/2 \text{ (height of screen)}) - 2.68" (68 \text{ mm})$

FRONT VIEW

RANGE	
R	3.75 TO 5.25 (95) (133)

TECHNICAL DATA SHEET

MODEL: PLCM UNL

ALL DIMENSION = INCH (MM)

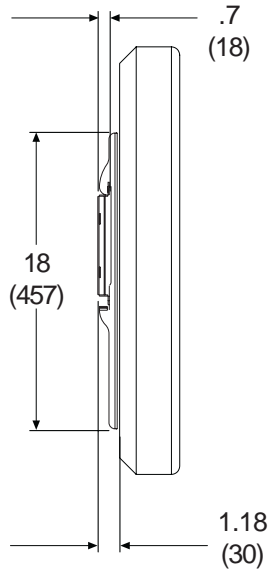

SIDE VIEW WITH SHALLOW BRACKET

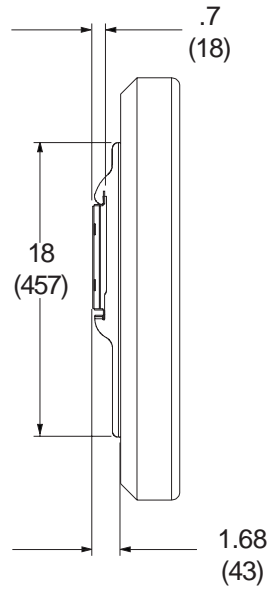

SIDE VIEW WITH DEEP BRACKET

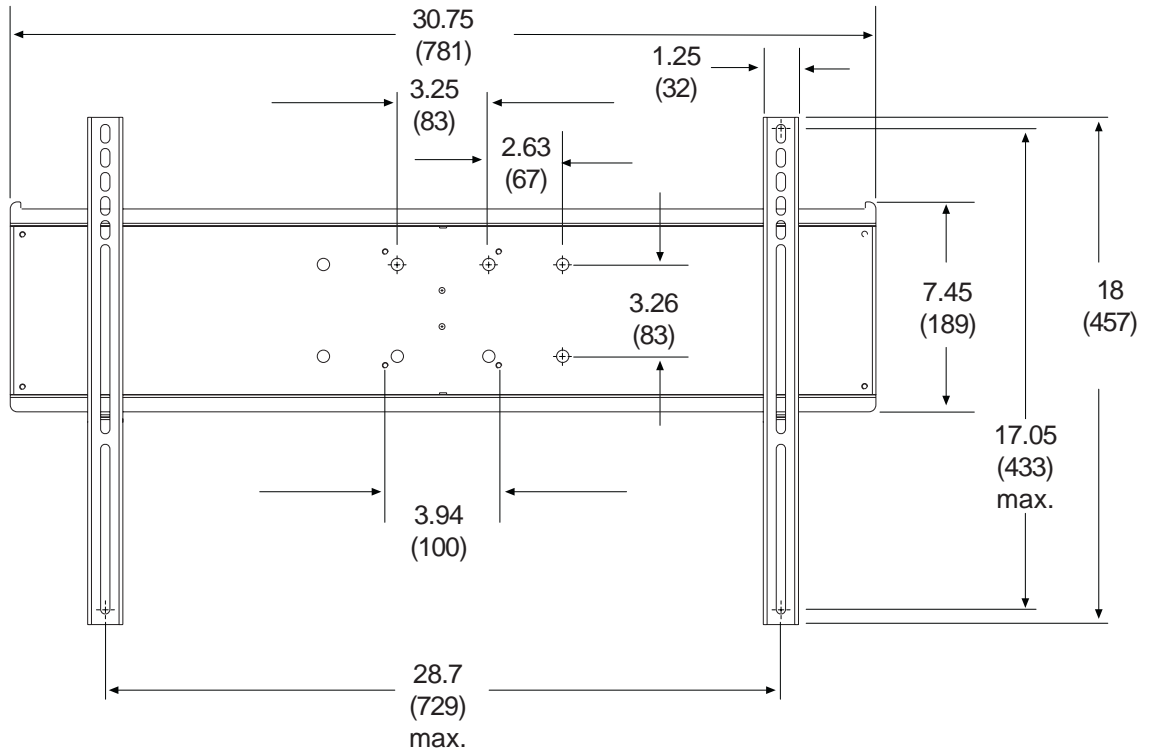

ADAPTER BRACKET DETAIL